



Overall Length



Other sizes available, consult factory.

2T SERIES, 2" (STAINLESS STEEL) SCREW PLUG HEATERS

WATTS	VOLTS	OVERALL LENGTH In./ (mm)	PIPE THREAD	NO. OF ELEMENTS	MODEL NUMBER	SHIP WGT. Lbs./ (kg)
2000	240	8	2	2	2T2208	5
	480	(205)			2T2408	(2.5)
3000	240	12	2	2	2T3212	6
	480	(305)			2T3412	(3)
4000	240	18	2	2	2T4218	7
	480	(460)			2T4418	(3.5)
6000	240	25	2	2	2T6225	8
	480	(635)			2T6425	(4)
8000	240	32	2	2	2T8232	10
	480	(815)			2T8432	(4.5)
10000	240	40	2	2	2T10240	10
	480	(1015)			2T10440	(4.5)
12000	480	48	2	2	2T12448	12
		(1220)				(5.5)
15000	480	54	2	2	2T15454	15
		(1370)				(7)

T2T SERIES, 2" (TITANIUM) SCREW PLUG HEATERS

WATTS	VOLTS	OVERALL LENGTH In./ (mm)	PIPE THREAD	NO. OF ELEMENTS	MODEL NUMBER	SHIP WGT. Lbs./ (kg)
2000	240	8	2	2	T2T2208	4
	480	(205)			T2T2408	(2)
4000	240	18	2	2	T2T4218	7
	480	(460)			T2T4418	(3.5)
6000	240	25	2	2	T2T6225	7
	480	(635)			T2T6425	(3.5)
8000	240	32	2	2	T2T8232	10
	480	(815)			T2T8432	(4.5)
12000	480	48	2	2	T2T12448	12
		(1220)				(5.5)

Product Features and Benefits:

- ◆ **SUPERIOR CHEMICAL RESISTANCE:** For use in most alkaline or aqueous plating solutions and rinse tanks. Check solution recommendation chart or with your chemical supplier for proper sheath material selection.
- ◆ **RUGGED CONSTRUCTION:** Heavy wall metal sheaths and screw plug in 316 stainless steel and titanium.
- ◆ **OUTSTANDING PERFORMANCE:** Watt densities of 40 watts per square inch (6.2 w/cm²) ensure long service life.
- ◆ **CORROSION RESISTANT HEAD:** Vapor resistant, flame retardant PVC enclosure.
- ◆ **SAFETY FEATURES:** Grounded construction.
- ◆ **CERTIFICATIONS:** UL listed to U.S. and Canadian safety requirements, and CE.
- ◆ **SIZES:**
 - 2,000 watts to 15,000 watts (316 stainless steel).
 - 2,000 watts to 12,000 watts (titanium).
- ◆ **VOLTAGES:** 120 to 600 volts. Single phase standard, three phase available on some models.
- ◆ **OPTIONS AVAILABLE** (consult factory):
 - Special configurations and lengths.
 - Thermowells.
 - Explosion resistant enclosures.
 - Carbon steel or incoloy elements.
 - Lower watt densities for highly viscous solutions.
 - Integral thermostats.
 - Temperature and level controls sized to match the heater.

DIMENSIONS

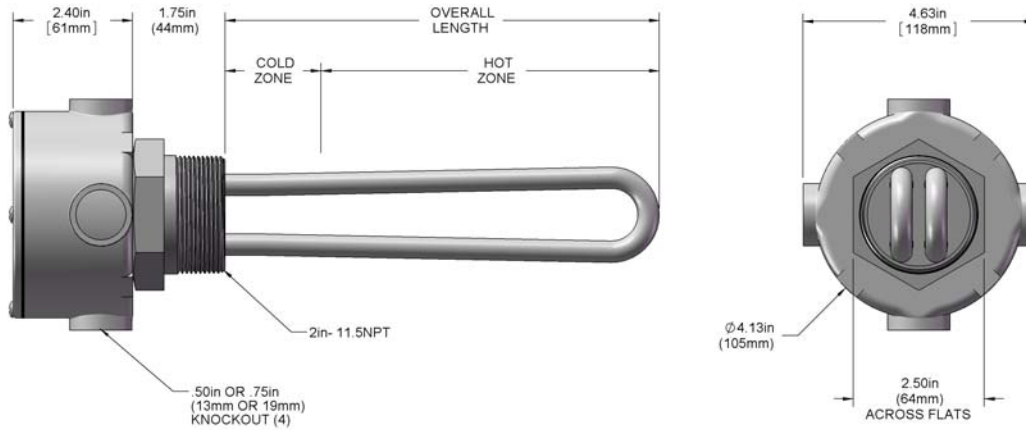

2T & T2T SERIES, 2" STAINLESS STEEL SCREW PLUG HEATER ORDERING INFORMATION

Series	Wattage	Voltage	Length (in.)	Options
<p>2 = 2000 3 = 3000 4 = 4000 6 = 6000 8 = 8000 10 = 10000 12 = 12000 15 = 15000</p>	<p>1 = 120 2 = 240 3 = 380 4 = 480 5 = 415 6 = 600 7 = 400 8 = 208 9 = 220 0 = 200</p>	<p>8 = 2kW 12 = 3kW 18 = 4kW 25 = 6kW 32 = 8kW 40 = 10kW (SS only) 48 = 12kW 54 = 15kW (SS only) (custom lengths available)</p>	<p>no designator = single phase power (standard) -3 = three phase power (three elements) -M2 = explosion/moisture resistant housing -W = thermowell -T = integral thermostat</p>	
<p>2T = 316 stainless steel T2T = titanium IN2T = incoloy</p>				

1 inch = 25.4mm

ORDERING EXAMPLE:

T2T8432-M2

2" NPT (pipe thread), titanium, 8000 watts, 480 volts, 32" overall length, explosion/moisture resistant housing.

