

3HXO SERIES, MULTI ELEMENT FLUOROPOLYMER (PTFE) HEATERS							
WATTS	VOLTS	WIDTH	HOT ZONE	OVERALL LENGTH	MAX. COLD ZONE	MODEL NUMBER	SHIP WGT.
		in./(mm)	in./(mm)	in./(mm)	in./(mm)		Lbs./ (kg)
1500	120	10	6	11	36	3HXO1.5110-06-11- <sup>**</sup>	15
	240	(255)	(155)	(280)	(915)	3HXO1.5210-06-11- <sup>**</sup>	(7)
3000	240	10	6	11	36	3HXO3210-06-11- <sup>**</sup>	20
	480	(255)	(155)	(280)	(915)	3HXO3410-06-11- <sup>**</sup>	(9.5)
4500	240	10	9.5	17	35	3HXO4.5210-9.5-17- <sup>**</sup>	21
	480	(255)	(245)	(430)	(890)	3HXO4.5410-9.5-17- <sup>**</sup>	(9.5)
6000	240	12	10.5	17	35	3HXO6212-10.5-17- <sup>**</sup>	22
	480	(305)	(270)	(430)	(890)	3HXO6412-10.5-17- <sup>**</sup>	(10)
9000	240	12	16	23	35	3HXO9212-16-23- <sup>**</sup>	36
	480	(305)	(405)	(585)	(890)	3HXO9412-16-23- <sup>**</sup>	(16.5)
12000	240	12	20.5	29	35	3HXO12212-20.5-29- <sup>**</sup>	42
	480	(305)	(525)	(735)	(890)	3HXO12412-20.5-29- <sup>**</sup>	(20)
15000	240	12	25	35	31	3HXO15212-25-35- <sup>**</sup>	48
	480	(305)	(635)	(890)	(790)	3HXO15412-25-35- <sup>**</sup>	(22)
18000	240	12	29	40	25	3HXO18212-29-40- <sup>**</sup>	54
	480	(305)	(735)	(1015)	(635)	3HXO18412-29-40- <sup>**</sup>	(24.5)
24000	240	14	36	47	28	6HXO24214-36-47- <sup>**</sup>	58
	480	(355)	(915)	(1195)	(710)	6HXO24414-36-47- <sup>**</sup>	(26.5)
27000	240	14	40	54	30	6HXO27214-40-54- <sup>**</sup>	64
	480	(355)	(1015)	(1370)	(760)	6HXO27414-40-54- <sup>**</sup>	(29)

Three phase standard.

## Product Features and Benefits:

- ◆ **SUPERIOR CHEMICAL RESISTANCE:** Inert to most aqueous acid, alkaline, anodizing and pickling solutions up to 212°F (100°C).
- ◆ **RUGGED CONSTRUCTION:** Heavy wall fluoropolymer (PTFE) covered stainless steel element reduces permeation and eliminates the need for gas purge systems. Guaranteed 100% pinhole free.
- ◆ **OUTSTANDING PERFORMANCE:** Low watt density design (10 watts/square inch, 1.5w/cm<sup>2</sup>) for long service life.
- ◆ **CORROSION RESISTANT HEAD:** Vapor tight, flame retardant polypropylene terminal enclosure with 3-foot (.9m) flexible PVC liquid tight conduit.
- ◆ **SAFETY FEATURES:**
  - Grounded internal metal element.
  - Thermal protector built in. Replaceable PT-I fuse standard for solutions up to 190°F (88°C).
  - Non-floating construction.
- ◆ **CERTIFICATIONS:** UL (1.5-18 kW), and CE.
- ◆ **SIZES:** 1,500 watts to 27,000 watts.
- ◆ **VOLTAGES:** 120, 240 or 480 volts. 208, 380, 415, 600 and other voltages available. Three phase standard, single phase available.
- ◆ **OPTIONS AVAILABLE** (consult factory):
  - Replaceable thermal protectors:
    - PT-IM: for solutions from 190°F (88°C) to 220°F (104°C).
  - Resettable thermal protectors:
    - PT-II bi-metal switch: for solutions up to 190°F (88°C).
    - PT-III type-J thermocouple for solutions from 190°F (88°C) to 210°F (99°C).
    - PIII type-J thermocouple for solutions from 210°F (99°C) to 250°F (121°C).
  - Longer vertical lengths (cold zones).
  - Polypropylene guards: recommended for applications up to 180°F (82°C).
  - Fluoropolymer (PTFE) guards: recommended for chromic acid or solutions over 180°F (82°C).
  - Special configurations.
  - Longer wire and conduit lengths.
  - Lower watt densities for highly viscous solutions and technical acids.
  - Temperature and level controls sized to match the heater.
  - Single phase voltage.

## DIMENSIONS (up to 18 kW)

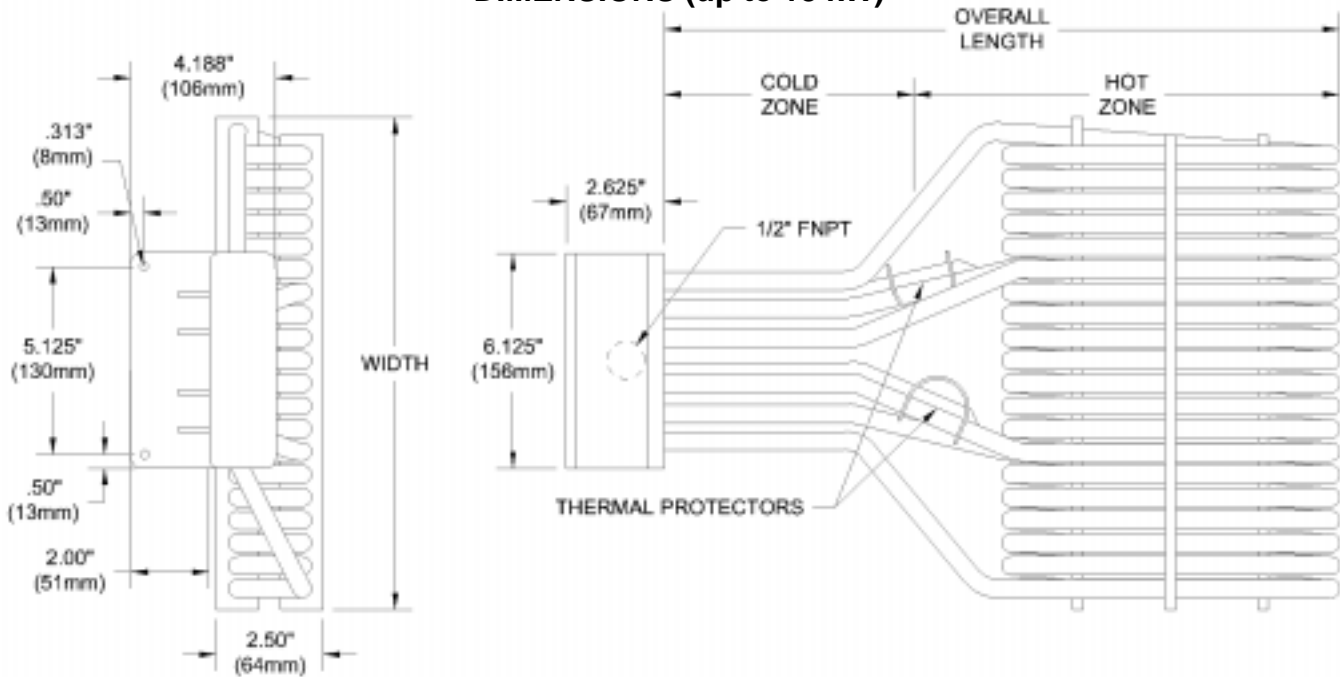

### MULTI ELEMENT OVER THE SIDE FLUOROPOLYMER (PTFE) HEATER

Series	Wattage	Voltage	Width	Hot Zone	Overall Length	Options	Type of Fuse	Wire and Conduit Length
	1.5 = 1500 3 = 3000 4.5 = 4500 6 = 6000 9 = 9000 12 = 12000 15 = 15000 18 = 18000 24 = 24000 27 = 27000	1 = 120 2 = 240 4 = 480 -208- = 208 -277- = 277 -380- = 380 -415- = 415 -600- = 600		-06 = 1.5kW -06 = 3kW -9.5 = 4.5kW -10.5 = 6kW -16 = 9kW -20.5 = 12kW -25 = 15kW -29 = 18kW -36 = 24kW -40 = 27kW				no designator = 36" length standard specify variations from standard Ex: -X84 = 84"
		10 = 1.5kW 10 = 3kW 10 = 4.5W 12 = 6kW 12 = 9kW 12 = 12kW 12 = 15kW 12 = 18kW 14 = 24kW 14 = 27kW		-11 = 1.5kW -11 = 3kW -17 = 4.5W -17 = 6kW -23 = 9kW -29 = 12kW -35 = 15kW -40 = 18kW -47 = 24kW -54 = 27kW				
	3HXO = 3 element PTFE sheathed 6HXO = 6 element PTFE sheathed 3HSO = 3 element 304 stainless steel 6HSO = 6 element 304 stainless steel			specify custom lengths, not to exceed tank length				
							<b>Replaceable Fuse</b> -PT-I (std) for solutions up to 190°F -PT-IM for 190° - 220°F solutions <b>Resettable Fuse</b> (additional control components required) -PT-II for solutions up to 190°F -PT-III for 190° - 210°F solutions -PIII for 210° - 250°F solutions	
							X = any special configuration not called out in the part number (specify in clear text) C = complete with guard no designator = three phase power (standard) -1 = single phase power	

### ORDERING EXAMPLE:

3HXO3210-06-11-PT-I-X50

Multi element fluoropolymer heater, 3000 watts, 240 volt, three phase, 10" wide, 6" hot zone, 11" overall length, PT-I thermal fuse, 50" wire and conduit

**PROCESS  
TECHNOLOGY**