

D3L SERIES, DERATED TRIPLE METAL L-SHAPED HEATERS							SHIP	
WATTS	VOLTS	STD.		STEEL	304 SS	316 SS	TITANIUM	SHIP WGT.
		HORIZ.	VERT.*					
		In./(mm)	In./(mm)					Lbs./(kg)
1500	120	13	15	D3LP1.5113-R**	D3LF1.5113-R**	D3LS1.5113-R**	D3LT1.5113-R**	30
	240	(330)	(380)	D3LP1.5213-R**	D3LF1.5213-R**	D3LS1.5213-R**	D3LT1.5213-R**	(14)
3000	240	17	37	D3LP3217-R**	D3LF3217-R**	D3LS3217-R**	D3LT3217-R**	33
	480	(430)	(940)	D3LP3417-R**	D3LF3417-R**	D3LS3417-R**	D3LT3417-R**	(15)
4500	240	22	37	D3LP4.5222-R**	D3LF4.5222-R**	D3LS4.5222-R**	D3LT4.5222-R**	36
	480	(560)	(940)	D3LP4.5422-R**	D3LF4.5422-R**	D3LS4.5422-R**	D3LT4.5422-R**	(16.5)
6000	240	26	37	D3LP6226-R**	D3LF6226-R**	D3LS6226-R**	D3LT6226-R**	39
	480	(660)	(940)	D3LP6426-R**	D3LF6426-R**	D3LS6426-R**	D3LT6426-R**	(18)
7500	240	31	37	D3LP7.5231-R**	D3LF7.5231-R**	D3LS7.5231-R**	D3LT7.5231-R**	42
	480	(790)	(940)	D3LP7.5431-R**	D3LF7.5431-R**	D3LS7.5431-R**	D3LT7.5431-R**	(19)
9000	240	36	50	D3LP9236-R**	D3LF9236-R**	D3LS9236-R**	D3LT9236-R**	45
	480	(915)	(1270)	D3LP9436-R**	D3LF9436-R**	D3LS9436-R**	D3LT9436-R**	(20.5)
12000	240	44	50	D3LP12244-R**	D3LF12244-R**	D3LS12244-R**	D3LT12244-R**	54
	480	(1120)	(1270)	D3LP12444-R**	D3LF12444-R**	D3LS12444-R**	D3LT12444-R**	(24.5)
13500	240	50	50	D3LP13.5250-R**	D3LF13.5250-R**	D3LS13.5250-R**	D3LT13.5250-R**	60
	480	(1270)	(1270)	D3LP13.5450-R**	D3LF13.5450-R**	D3LS13.5450-R**	D3LT13.5450-R**	(27.5)
15000	240	55	50	D3LP15255-R**	D3LF15255-R**	D3LS15255-R**	D3LT15255-R**	66
	480	(1400)	(1270)	D3LP15455-R**	D3LF15455-R**	D3LS15455-R**	D3LT15455-R**	(30)
18000	240	64	50	D3LP18264-R**	D3LF18264-R**	D3LS18264-R**	D3LT18264-R**	75
	480	(1625)	(1270)	D3LP18464-R**	D3LF18464-R**	D3LS18464-R**	D3LT18464-R**	(34)

* Specify vertical length by adding height in inches after "R". Example: D3LS3217-R36-P1.

Product Features and Benefits:

- ◆ **SUPERIOR CHEMICAL RESISTANCE:** Materials available for use in most aqueous alkaline solutions, plating solutions, and rinse tanks. Check solution recommendation chart or with your chemical supplier for proper sheath material selection.
- ◆ **RUGGED CONSTRUCTION:** Heavy wall metal sheaths available in:
 - Steel.
 - 304 stainless steel.
 - 316 stainless steel.
 - Titanium.
- ◆ **OUTSTANDING PERFORMANCE:** Low watt densities of 18 watts per square inch (2.8 w/cm²) extend service life. Two-inch sludge legs standard, other lengths available.
- ◆ **EVEN HEATING:** Bottom heating design for even heating and varying liquid levels.
- ◆ **CORROSION RESISTANT HEAD:** Vapor resistant, flame retardant polypropylene terminal enclosure with 3-foot (.9m) flexible PVC liquid tight conduit.
- ◆ **SAFETY FEATURES:**
 - Grounded construction.
 - Thermal protector built in. Replaceable P1 protector standard for solutions up to 180°F (82°C).
 - Non-floating construction.
- ◆ **CERTIFICATIONS:** UL listed (except steel) to U.S. and Canadian safety requirements, and CE.
- ◆ **SIZES:** 1,500 watts to 18,000 watts.
- ◆ **VOLTAGES:** 120-600 volts. Three phase standard, single phase available.
- ◆ **OPTIONS AVAILABLE** (consult factory):
 - Replaceable thermal protectors:
 - P4: for solutions from 180°F (82°C) to 230°F (110°C).
 - P5: for solutions from 230°F (110°C) to 300°F (150°C).
 - Resettable thermal protectors:
 - P2: for solutions up to 180°F (82°C).
 - P6: for solutions from 180°F (82°C) to 230°F (110°C).
 - P7: for solutions from 230°F (110°C) to 300°F (150°C).
 - Special configurations and vertical lengths.
 - Longer wire and conduit lengths.
 - Longer sludge legs.
 - Flexible risers (available with P2 thermal protectors only).
 - Lower watt densities for highly viscous solutions.
 - Temperature and level controls sized to match the heater.

DIMENSIONS

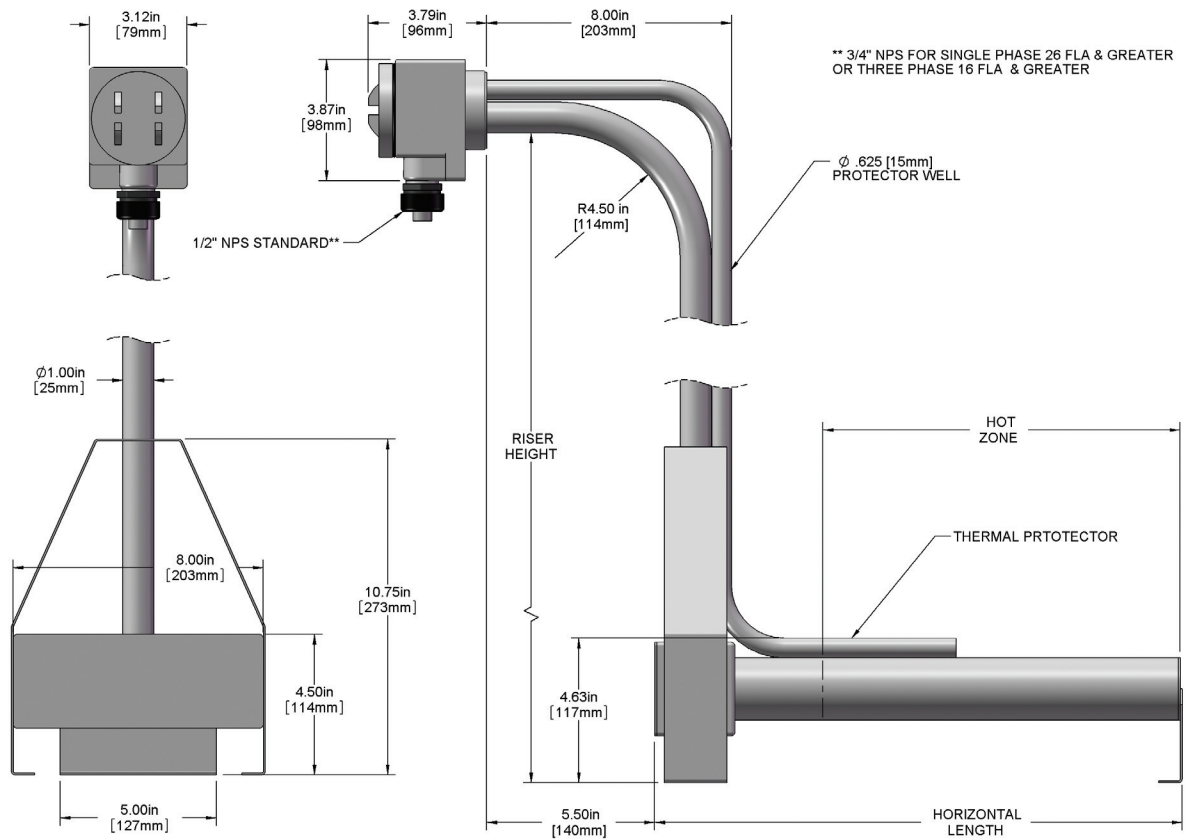

DERATED TRIPLE TUBE METAL L-SHAPED HEATER ORDERING INFORMATION

Series	Wattage	Voltage	Horizontal Length (in.)	Vertical Length (in.)	Riser Option	Options	Type of Protector	Wire and Conduit Length
	1.5 = 1500 3 = 3000 4.5 = 4500 6 = 6000 7.5 = 7500 9 = 9000 12 = 12000 13.5 = 13500 15 = 15000 18 = 18000	1 = 120 2 = 240 3 = 380 4 = 480 5 = 415 6 = 600 7 = 400 8 = 208 9 = 220 0 = 200	13 = 1.5kW 17 = 3kW 22 = 4.5kW 26 = 6kW 31 = 7.5kW 36 = 9kW 44 = 12kW 50 = 13.5kW 55 = 15kW 64 = 18kW	-R15 = 1.5kW -R37 = 3kW -R37 = 4.5kW -R37 = 6kW -R37 = 7.5kW -R50 = 9kW -R50 = 12kW -R50 = 13kW -R50 = 15kW -R50 = 18kW (custom lengths available) Ex: -R21 = 21" -FR = flex riser Ex: -FR21 = 21"				no designator = 36" length standard specify variations from standard Ex: -X84 = 84"
	D3LP = steel D3LF = 304 stainless steel D3LS = 316 stainless steel D3LT = titanium						Replaceable Protector -P1 for solutions up to 180°F -P4 for 180° - 230°F solutions -P5 for 230° - 300°F solutions Resettable Protector (additional control components required) -P2 for solutions up to 180°F -P6 for 180° - 230°F solutions -P7 for 230° - 300°F solutions	
			no designator = 90° horizontal bend (standard) -S = straight riser				no designator = three phase power (standard) -1 = single phase power 1 inch = 25.4mm	

ORDERING EXAMPLE:

D3LF12444-R50-P4-X72

Derated, L-shaped, triple tube, 304 SS, 12,000 watts, 480 volt, 44" length, 50" vertical riser, P4 protector, 72" wire & conduit

