

Metal Heat Exchanger Installation

HOT WATER OR COOLING APPLICATIONS:

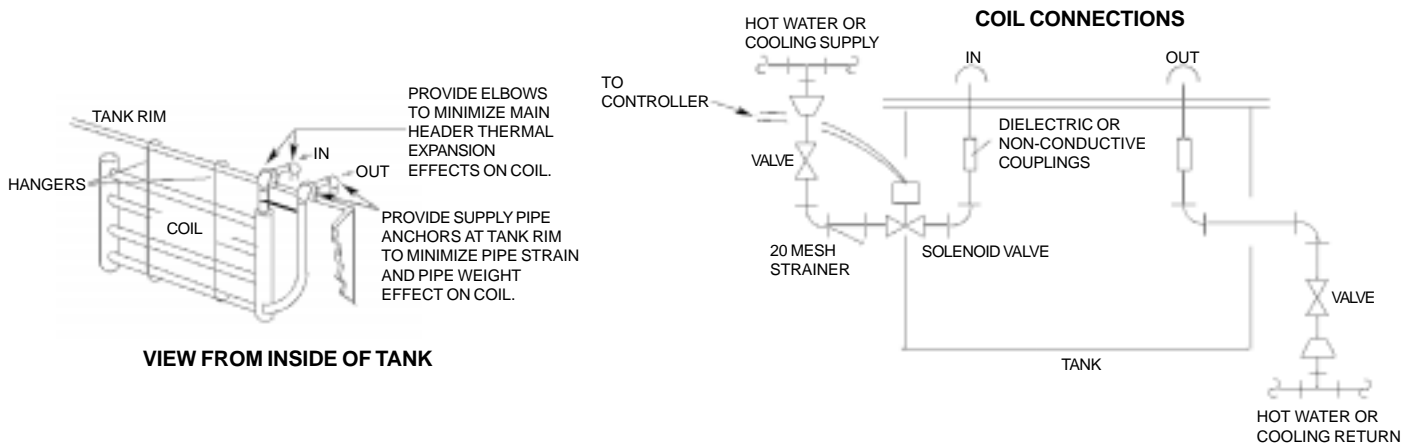

**FIGURE 1
CONTROL WIRING DIAGRAM**

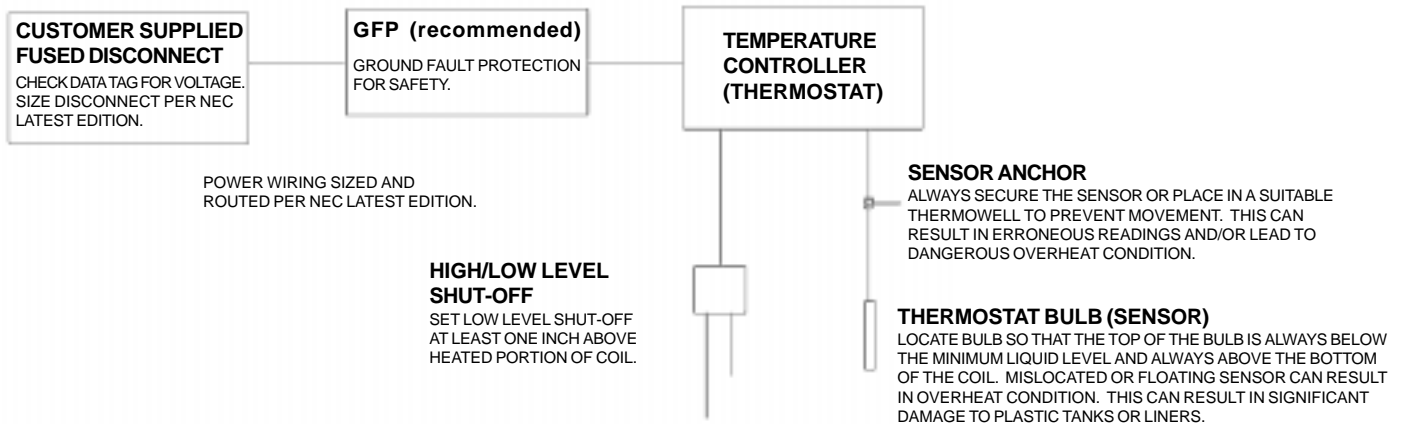

IMPORTANT

Protect coil from physical damage or contact with electrically charged tank.

The use of heating/cooling supply and return piping that is compatible with the chemical contents of the tank is strongly encouraged because any coil leak may siphon the tank contents into the cooling system. Coil leaks may cause tank overflows or may siphon tank contents. This risk can be lessened by turning off supply/discharge valving when system is not in use.

The use of high/low liquid level detection/alarm systems in conjunction with frequent coil and system inspections are recommended.

Do not exceed the pressure or temperature rating of the coil, as property loss and personal injury may result.

Wear protective gloves, clothing and eye wear when installing or servicing this product.

Warning: Hot surfaces. Verify temperature, pressure rating and application of exchanger before installation.

STEAM APPLICATIONS:

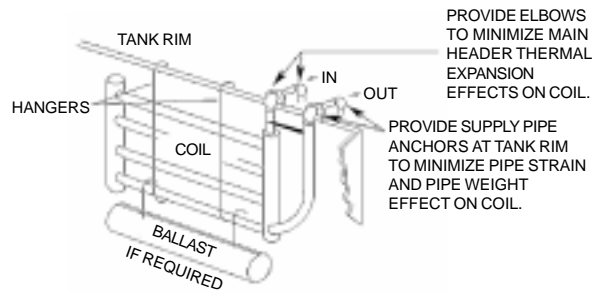

VIEW FROM INSIDE OF TANK

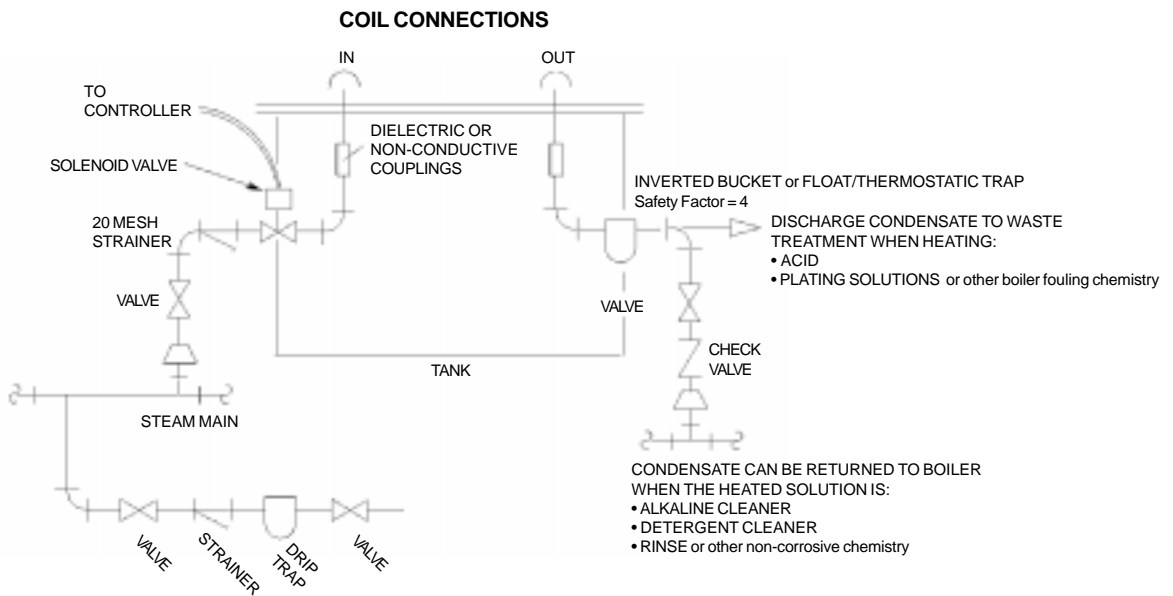

NOTE: For control and electrical wiring, refer to the wiring diagram (figure 1) on reverse.

IMPORTANT

Protect coil from physical damage.

Trap should be mounted 12-18" below outlet of exchanger. Do not install trap above exchanger or discharge to a vertical condensate line above trap/exchanger, as condensate flooding and improper operation will result. Each exchanger should be independently plumbed with a separate valve, trap and strainer.

Relying on a condensate analyzer/diverter to detect a coil leak is not recommended since the reliability of such systems is based on the maintenance received.

Any coil leak can result in tank overflows or the siphoning of the tank contents into the condensate system. Severe damage to the condensate system and the boiler may result.

The use of high/low liquid level detection/alarm systems in conjunction with frequent coil and system inspections are recommended.

Do not exceed the pressure or temperature rating of the coil, as property loss and personal injury may result.

Wear protective gloves, clothing and eye wear when installing or servicing this product.

Warning: Hot surfaces. Verify temperature, pressure rating and application of exchanger before installation.

