

Table of Contents

HX & HXL Fluoropolymer Heaters 3
HXF & HXFL Fluoropolymer Heaters 4
HXO & 3HXO Fluoropolymer Heaters 5
3HXOL Fluoropolymer Heaters 6
3HX & 6HX Fluoropolymer Heaters 7

9HX Fluoropolymer Heaters 8
HXRL Fluoropolymer Heaters 9
HXSL Fluoropolymer Heaters 11
HXOL Fluoropolymer Heaters 12
QM Quartz Heaters 14

3QM Quartz Heaters 16
P, F, S, & T Metal Over The Side Heaters 17
3P, 3F, 3S & 3T Metal Over The Side Heaters 18
D Metal Over The Side Heaters 19
D3 Metal Over The Side Heaters 20

L Metal L-Shaped Heaters 21
3L Metal L-Shaped Heaters 22
3LV Metal L-Shaped Heaters 23
DL Metal L-Shaped Heaters 24
D3L Metal L-Shaped Heaters 25

Deep Tank Metal & Triple Metal Heaters 26
3HS, 6HS & 9HS Stainless Steel Heaters 27
DAS Phosphate & V Varipower Heaters 28
QMB & B Small Tank Heaters 29
Tytan Heaters 30

T & 2T Screw Plug Heaters 31
5T, T2T & T5T Screw Plug Heaters 32
VST, VXT, TB & HXT Screw Plug Heaters 33
3FLX & 6FLX Flanged Fluoropolymer Heaters 34
3FLS & 5FLS Flanged Metal Heaters 35

6FLS & 8FLS Flanged Metal Heaters 36
10FLS & 12FLS Flanged Metal Heaters 37
14FLS Flanged Metal Heaters 38
R Series Quartz Infrared Heating Elements 39
Grid Coils 41

Serpentine Coils.....	44
U Coils	45
X & CX Fluoropolymer Heat Exchangers.....	46
CXL, 3CX & 3CXL Fluoropolymer Heat Exchangers	47
Thermax Heat Exchangers	48
Brass Solenoid Valves	49
ST Strainers, IX Insulators & VB Vacuum Breakers.....	50
NR Thermostats and Combination Controls.....	51
NE Thermostats and Combination Controls.....	52
DE Digital Thermostats and Combination Controls.....	53
DQ Digital Thermostats and Combination Controls	54
DSL Digital Thermostats and Combination Controls.....	55
DLC Digital Thermostats and Combination Controls.....	56
LC & ESP Liquid Level Controls	57
ETI Series, DTS Series, AHM Series & W Series	58
SD Series Conduit & Fittings.....	59
Appendix.....	60

HX & HXL Fluoropolymer Heaters

HX SERIES, SPIRAL FLUOROPOLYMER (PTFE) HEATERS (Single Phase Only) (pg A1)								
Model Number	Length	Width	Height	Dim. Wt. Domestic Air	Dim. Wt. International Air & Ground	Actual Weight LBS./ (kg)	Shipping Weight Ground	Box Girth
HX.5111-** HX.5211-**	20	9	10	10	11	6 (2.5)	6	58
HX1111-** HX1211-**	20	9	10	10	11	7 (3.5)	7	58
HX2117-** HX2217-** HX2417-**	24	11	12	17	20	8 (4)	8	70
HX3223-** HX3423-**	33	13	12	27	32	13 (6)	13	83
HX4229-** HX4429-**	42	12	12	32	37	15 (7)	32	90
HX5235-** HX5435-**	42	12	12	32	37	18 (8)	32	90
HX6240-** HX6440-**	44	13	12	36	42	21 (10)	36	94
2HX8247-** 2HX8447-**	55	13	12	45	52	25 (12)	45	105
2HX9254-** 2HX9454-**	62	13	12	50	59	28 (13)	50	112

HXL SERIES, SPIRAL L-SHAPED FLUOROPOLYMER (PTFE) HEATERS (Single Phase Only) (pg A2)								
Model Number	Length	Width	Height	Dim. Wt. Domestic Air	Dim. Wt. International Air & Ground	Actual Weight LBS./ (kg)	Shipping Weight Ground	Box Girth
HXL.5106-R*-** HXL.5206-R*-**	20	9	10	10	11	6 (2.5)	6	58
HXL1108-R*-** HXL1208-R*-**	24	11	12	17	20	7 (3.5)	7	70
HXL2112-R*-** HXL2212-R*-** HXL2412-R*-**	33	13	12	27	32	8 (4)	8	83
HXL3217-R*-** HXL3417-R*-**	24	12	22	33	39	13 (6)	33	92
HXL4220-R*-** HXL4420-R*-**	24	12	24	36	42	15 (7)	36	96
HXL5224-R*-** HXL5424-R*-**	33	14	24	58	67	18 (8)	58	109
HXL6229-R*-** HXL6429-R*-**	33	14	24	58	67	21 (10)	58	109
2HXL8237-R*-** 2HXL8437-R*-**	42	12	24	63	73	25 (12)	63	114
2HXL9244-R*-** 2HXL8444-R*-**	48	14	24	84	98	28 (13)	84	124

*******IF SHIPMENT CONTAINS MULTIPLE CARTONS OVER 130" IN GIRTH OR A COMBINED ACTUAL WEIGHT OVER 200 LBS. - LTL FREIGHT IS RECOMMENDED**

HXF & HXFL Fluoropolymer Heaters

HXF SERIES, LOW PROFILE FLUOROPOLYMER (PTFE) HEATERS (Single Phase Only) (pg A3)								
Model Number	Length	Width	Height	Dim. Wt. Domestic Air	Dim. Wt. International Air & Ground	Actual Weight LBS./ (kg)	Shipping Weight Ground	Box Girth
HXF.5105-14-** HXF.5205-14-**	20	9	10	10	11	6 (2.5)	6	58
HXF1106-14-** HXF1206-14-**	20	9	10	10	11	7 (3.5)	7	58
HXF2108-17-** HXF2208-17-** HXF2408-17-**	24	11	12	17	20	8 (4)	8	70
HXF3209-23-** HXF3409-23-**	33	13	12	27	32	13 (6)	13	83
HXF4211-29-** HXF4411-29-**	42	12	12	32	37	15 (7)	32	90
HXF5212-35-** HXF5412-35-**	42	12	12	32	37	18 (8)	32	90
HXF6213-40-** HXF6413-40-**	48	13	12	39	46	21 (10)	39	98

HXFL SERIES, LOW PROFILE L-SHAPED FLUOROPOLYMER (PTFE) HEATERS (Single Phase Only) (pg A4)								
Model Number	Length	Width	Height	Dim. Wt. Domestic Air	Dim. Wt. International Air & Ground	Actual Weight LBS./ (kg)	Shipping Weight Ground	Box Girth
HXFL.5105-R*-** HXFL.5205-R*-**	20	9	10	10	11	6 (2.5)	6	58
HXFL1106-R*-** HXFL1206-R*-**	20	9	10	10	11	7 (3.5)	7	58
HXFL2108-R*-** HXFL2208-R*-** HXFL2408-R*-**	24	11	12	17	20	8 (4)	8	70
HXFL3209-R*-** HXFL3409-R*-**	24	11	12	17	20	13 (6)	13	70
HXFL4211-R*-** HXFL4411-R*-**	33	13	12	27	32	15 (7)	15	83
HXFL5212-R*-** HXFL5412-R*-**	36	15	15	42	49	18 (8)	42	96
HXFL6213-R*-** HXFL6413-R*-**	36	15	15	42	49	21 (10)	42	96

*******IF SHIPMENT CONTAINS MULTIPLE CARTONS OVER 130" IN GIRTH OR A COMBINED ACTUAL WEIGHT OVER 200 LBS. - LTL FREIGHT IS RECOMMENDED**

HXO & 3HXO Fluoropolymer Heaters

HXO SERIES, FLUOROPOLYMER (PTFE) HEATERS (Single Phase Only) (pg A5)									
Model Number	Length	Width	Height	Dim. Wt. Domestic Air	Dim. Wt. International Air & Ground	Actual Weight LBS./(kg)	Shipping Weight Ground	Add'l Shipping Charges	Box Girth
HXO.5105-06-11-** HXO.5205-06-11-**	20	9	10	10	11	6 (2.5)	6		58
HXO1106-06-11-** HXO1206-06-11-**	20	9	10	10	11	7 (3.5)	7		58
HXO2106-10-17-** HXO2206-10-17-** HXO2406-10-17-**	24	11	12	17	20	8 (4)	8		70
HXO3206-12-23-** HXO3406-12-23-**	33	13	12	27	32	13 (6)	13		83
HXO4206-19-29-** HXO4406-19-29-**	33	13	12	27	32	15 (7)	15		83
HXO5206-20-35-** HXO5406-20-35-**	42	12	12	32	37	18 (8)	32		90
HXO6206-22-40-** HXO6406-22-40-**	48	13	12	39	46	22 (10)	39		98
2HXO8206-36-47-** 2HXO8406-36-47-**	55	13	12	45	52	25 (11.5)	45		105
2HXO9206-40-54-** 2HXO9406-40-54-**	62	13	12	50	59	28 (13)	50		112

3HXO SERIES, MULTI ELEMENT FLUOROPOLYMER (PTFE) HEATERS (pg A6)									
Model Number	Length	Width	Height	Dim. Wt. Domestic Air	Dim. Wt. International Air & Ground	Actual Weight LBS./(kg)	Shipping Weight Ground	Add'l Shipping Charges	Box Girth
3HXO1.5110-06-11-** 3HXO1.5210-06-11-**	24	11	12	17	20	15 (7)	15		70
3HXO3210-06-1-** 3HXO3410-06-11-**	24	11	12	20	20	20 (9)	20		70
3HXO4.5210-9.5-17-** 3HXO4.5410-9.5-17-**	24	11	12	21	21	21 (9.5)	21		70
3HXO6212-10.5-17-** 3HXO6412-10.5-17-**	33	13	12	27	32	22 (10)	21		83
3HXO9212-16-23-** 3HXO9412-16-23-**	33	13	12	36	36	36 (16.5)	36		83
3HXO12212-20.5-29-** 3HXO12412-20.5-29-**	42	12	12	42	42	42 (20)	42		90
3HXO15212-25-35-** 3HXO15412-25-35-**	44	13	12	48	48	48 (22)	48		94
3HXO18212-29-40-** 3HXO18412-29-40-**	48	13	12	54	54	54 (24.5)	54		98
6HXO24214-36-47-** 6HXO24414-36-47-**	55	14	24	96	112	58 (26.5)	96	\$40	131 ****
6HXO27214-40-54-** 6HXO27414-40-54-**	62	14	24	108	126	64 (29)	108	\$40	138 ****

*****IF SHIPMENT CONTAINS MULTIPLE CARTONS OVER 130" IN GIRTH OR A COMBINED ACTUAL WEIGHT OVER 200 LBS. - LTL FREIGHT IS RECOMMENDED

3HXOL Fluoropolymer Heaters

3HXOL SERIES, MULTI ELEMENT L-SHAPED FLUOROPOLYMER (PTFE) HEATERS (pg A7)									
Model Number	Length	Width	Height	Dim. Wt. Domestic Air	Dim. Wt. International Air & Ground	Actual Weight LBS./(kg)	Shipping Weight Ground	Add'l Shipping Charges	Box Girth
3HXOL3207-13-R*-** 3HXOL3407-13-R*-**	33	13	12	27	32	20 (9)	20		83
3HXOL4.5209-10-R*-** 3HXOL4.5409-10-R*-**	33	13	12	27	32	21 (9.5)	21		83
3HXOL6210-19-R*-** 3HXOL6410-19R*-**	33	14	25	60	70	29 (14)	60		111
3HXOL9210-23-R*-** 3HXOL9410-23-R*-**	33	14	25	60	70	36 (16.5)	60		111
3HXOL12210-30-R*-** 3HXOL12410-30-R*-**	44	14	25	80	93	42 (20)	80		122
3HXOL15210-36-R*-** 3HXOL15410-36-R*-**	44	14	25	80	93	48 (22)	80		122
3HXOL18210-42-R*-** 3HXOL18410-42-R*-**	48	14	25	87	102	54 (24.5)	87		126
6HXOL24214-40-R*-** 6HXOL24414-40-R*-**	49	18	25	114	133	58 (26.5)	114	\$40	135 ****
6HXOL27214-45-R*-** 6HXOL27414-45-R*-**	49	18	25	114	133	64 (29)	114	\$40	135 ****

*******IF SHIPMENT CONTAINS MULTIPLE CARTONS OVER 130" IN GIRTH OR A COMBINED ACTUAL WEIGHT OVER 200 LBS. - LTL FREIGHT IS RECOMMENDED**

3HX & 6HX Fluoropolymer Heaters

3HX SERIES, 3 ELEMENT FLUOROPOLYMER (PTFE) HEATERS (pg A8)								
Model Number	Length	Width	Height	Dim. Wt. Domestic Air	Dim. Wt. International Air & Ground	Actual Weight LBS./(kg)	Shipping Weight Ground	Box Girth
3HX1117-1-** 3HX1217-**	24	11	12	17	20	10 (4.5)	10	70
3HX1.5123-1-** 3HX1.5223-** 3HX1.5423-**	33	13	12	27	32	11 (5)	11	83
3HX2229-** 3HX2429-**	33	13	12	27	32	12 (5.5)	11	83
3HX3235-** 3HX3435-**	42	12	12	32	37	14 (6.5)	32	90
3HX4247-** 3HX4447-**	55	13	12	45	52	17 (8)	45	105
3HX5259-** 3HX5459-**	67	13	12	54	63	20 (9)	54	117
3HX6268-** 3HX6468-**	80	13	12	65	76	23 (10.5)	65	130 *****

6HX SERIES, 6 ELEMENT FLUOROPOLYMER (PTFE) HEATERS (pg A9)								
Model Number	Length	Width	Height	Dim. Wt. Domestic Air	Dim. Wt. International Air & Ground	Actual Weight LBS./(kg)	Shipping Weight Ground	Box Girth
6HX2117-1-** 6HX2217-** 6HX2417-**	33	13	12	27	32	19 (8.5)	19	83
6HX3223-** 6HX3423-**	33	13	12	27	32	22 (10)	22	83
6HX4229-** 6HX4429-**	42	12	12	32	37	24 (11)	32	90
6HX6235-** 6HX6435-**	42	12	12	32	37	27 (12.5)	32	90
6HS8247-** 6HX8447-**	55	13	12	45	52	33 (15)	45	105
6HX10259-** 6HX10459-**	67	13	12	54	63	40 (18)	54	117
6HX12268-** 6HX12468-**	80	13	12	65	76	45 (20.5)	65	130 *****

*****IF SHIPMENT CONTAINS MULTIPLE CARTONS OVER 130" IN GIRTH OR A COMBINED ACTUAL WEIGHT OVER 200 LBS. - LTL FREIGHT IS RECOMMENDED

9HX Fluoropolymer Heaters

9HX SERIES, 9 ELEMENT FLUOROPOLYMER (PTFE) HEATERS (pg A10)								
Model Number	Length	Width	Height	Dim. Wt. Domestic Air	Dim. Wt. International Air & Ground	Actual Weight LBS./(kg)	Shipping Weight Ground	Box Girth
9HX3217-** 9HX3417-**	33	13	12	28	32	28 (13)	28	83
9HX4.5223-** 9HX4.5423-**	33	13	12	33	33	33 (15)	33	83
9HX6229-** 9HX6429-**	44	13	12	36	42	36 (16.5)	36	94
9HX9235-** 9HX9435-**	44	13	12	40	42	40 (18)	40	94
9HX12247-** 9HX12447-**	55	13	12	49	52	49 (22.5)	49	105
9HX15259-** 9HX15459-**	67	13	12	60	63	60 (27.5)	60	117
9HX18268-** 9HX18468-**	80	13	12	67	76	67 (30.5)	67	130 *****

*******IF SHIPMENT CONTAINS MULTIPLE CARTONS OVER 130" IN GIRTH OR A COMBINED ACTUAL WEIGHT OVER 200 LBS. - LTL FREIGHT IS RECOMMENDED**

HXRL Fluoropolymer Heaters

HXRL SERIES, FLEX RISER FLOUROPOLYMER HEATERS (pg A11)								
Model Number	Length	Width	Height	Dim. Wt. Domestic Air	Dim. Wt. International Air & Ground	Actual Weight LBS./(kg)	Shipping Weight Ground	Box Girth
HXRL1104-19L-** HXRL1204-19L-**	24	11	12	17	20	7 (3.5)	7	70
HXRL1106-13L-** HXRL1206-13L-**	24	11	12	17	20	7 (3.5)	7	70
HXRL1108-10L-** HXRL1208-10L-**	24	11	12	17	20	7 (3.5)	7	70
HXRL2106-25L-** HXRL2206-25L-** HXRL2406-25L-**	33	13	12	27	32	10 (4.5)	10	83
HXRL2108-19L-** HXRL2208-19L-** HXRL2408-19L-**	21	17	13	24	28	10 (4.5)	10	81
HXRL2110-15L-** HXRL2210-15L-** HXRL2410-15L-**	21	17	13	24	28	10 (4.5)	10	81
HXRL2112-13L-** HXRL2212-13L-** HXRL2412-13L-**	21	17	13	24	28	10 (4.5)	10	81
HXRL2114-11L-** HXRL2214-11L-** HXRL2414-11L-**	21	17	13	24	28	10 (4.5)	10	81
HXRL3210-23L-** HXRL3410-23L-**	33	13	12	27	32	12 (5.5)	12	83
HXRL3212-19L-** HXRL3412-19L-**	21	17	13	24	28	12 (5.5)	12	81
HXRL3214-16L-** HXRL3414-16L-**	21	17	13	24	28	12 (5.5)	12	81
HXRL3216-14L-** HXRL3416-14L-**	21	17	13	24	28	12 (5.5)	12	81

*******IF SHIPMENT CONTAINS MULTIPLE CARTONS OVER 130" IN GIRTH OR A COMBINED ACTUAL WEIGHT OVER 200 LBS. - LTL FREIGHT IS RECOMMENDED**

HXRL Fluoropolymer Heaters (cont.)

HXRL SERIES, FLEX RISER FLOUROPOLYMER HEATERS (cont.) (pg A11)								
Model Number	Length	Width	Height	Dim. Wt. Domestic Air	Dim. Wt. International Air & Ground	Actual Weight LBS./(kg)	Shipping Weight Ground	Box Girth
HXRL3218-13L-** HXRL3418-13L-**	21	17	13	24	28	12 (5.5)	12	81
HXRL4212-25L-** HXRL4412-25L-**	33	13	24	54	63	14 (6.5)	54	107
HXRL4214-22L-** HXRL4414-22L-**	36	15	15	42	49	14 (6.5)	42	96
HXRL4216-19L-** HXRL4416-19L-**	21	17	13	24	28	14 (6.5)	14	81
HXRL4218-17L-** HXRL4418-17L-**	21	17	13	24	28	14 (6.5)	14	81
HXRL4220-15L-** HXRL4420-15L-**	24	12	20	30	35	14 (6.5)	30	88
HXRL5212-31L-** HXRL5412-31L-**	33	13	24	54	63	17 (8)	54	107
HXRL5214-27L-** HXRL5414-27L-**	36	15	15	42	49	17 (8)	42	96
HXRL5216-24L-** HXRL5416-24L-**	36	15	15	42	49	17 (8)	42	96
HXRL5218-21L-** HXRL5418-21L-**	37	27	15	78	91	17 (8)	78	121
HXRL6212-36L-** HXRL6412-36L-**	44	13	12	36	42	20 (9)	36	94
HXRL6214-30L-** HXRL6414-30L-**	36	15	15	42	49	20 (9)	42	96
HXRL6216-26L-** HXRL6416-26L-**	37	27	15	78	91	20 (9)	78	121
HXRL6220-21L-** HXRL6420-21L-**	37	27	15	78	91	20 (9)	78	121

*******IF SHIPMENT CONTAINS MULTIPLE CARTONS OVER 130" IN GIRTH OR A COMBINED ACTUAL WEIGHT OVER 200 LBS. - LTL FREIGHT IS RECOMMENDED**

HXSL Fluoropolymer Heaters

HXSL SERIES, FLEX RISER FLOUROPOLYMER HEATERS (pg A13)								
Model Number	Length	Width	Height	Dim. Wt. Domestic Air	Dim. Wt. International Air & Ground	Actual Weight LBS./ (kg)	Shipping Weight Ground	Box Girth
HXSL1000-**				*	*	7 (3.5)	N/A	*
HXSL2000-**				*	*	10 (4.5)	N/A	*
HXSL3000-**				*	*	12 (5.5)	N/A	*
HXSL4000-**				*	*	14 (6.5)	N/A	*
HXSL5000-**				*	*	17 (8)	N/A	*
HXSL6000-**				*	*	20 (9)	N/A	*

* Based on heater size selected

*******IF SHIPMENT CONTAINS MULTIPLE CARTONS OVER 130" IN GIRTH OR A COMBINED ACTUAL WEIGHT OVER 200 LBS. - LTL FREIGHT IS RECOMMENDED**

HXOL Fluoropolymer Heaters

HXOL SERIES, FLEX RISER FLOUROPOLYMER HEATERS (pg A12)								
Model Number	Length	Width	Height	Dim. Wt. Domestic Air	Dim. Wt. International Air & Ground	Actual Weight LBS./ (kg)	Shipping Weight Ground	Box Girth
HXOL1102-11L-** HXOL1202-11L-**	20	9	10	10	11	7 (3.5)	7	58
HXOL1104-08L-** HXOL1204-08L-**	20	9	10	10	11	7 (3.5)	7	58
HXOL2104-13L-** HXOL2204-13L-** HXOL2404-13L-**	20	9	10	10	11	10 (4.5)	10	58
HXOL2105-10L-** HXOL2205-10L-** HXOL2405-10L-**	20	9	10	10	11	10 (4.5)	10	58
HXOL2106-08L-** HXOL2206-08L-** HXOL2406-08L-**	20	9	10	10	11	10 (4.5)	10	58
HXOL3204-18L-** HXOL3404-18L-**	24	11	12	17	20	12 (5.5)	12	70
HXOL3205-12L-** HXOL3405-12L-**	24	11	12	17	20	12 (5.5)	12	70
HXOL3206-11L-** HXOL3406-11L-**	24	11	12	17	20	12 (5.5)	12	70
HXOL3208-08L-** HXOL3408-08L-**	21	17	13	24	28	12 (5.5)	12	81
HXOL4205-18L-** HXOL4405-18L-**	21	17	13	24	28	14 (6.5)	14	81

*******IF SHIPMENT CONTAINS MULTIPLE CARTONS OVER 130" IN GIRTH OR A COMBINED ACTUAL WEIGHT OVER 200 LBS. - LTL FREIGHT IS RECOMMENDED**

HXOL Fluoropolymer Heaters (cont.)

HXOL SERIES, FLEX RISER FLOUROPOLYMER HEATERS (cont.) (pg A12)								
Model Number	Length	Width	Height	Dim. Wt. Domestic Air	Dim. Wt. International Air & Ground	Actual Weight LBS./ (kg)	Shipping Weight Ground	Box Girth
HXOL4206-14L-** HXOL4406-14L-**	21	17	13	24	28	14 (6.5)	14	81
HXOL4208-11L-** HXOL4408-11L-**	21	17	13	24	28	14 (6.5)	14	81
HXOL5206-18L-** HXOL5406-18L-**	21	17	13	24	28	17 (8)	17	81
HXOL5208-13L-** HXOL5408-13L-**	21	17	13	24	28	17 (8)	17	81
HXOL5209-11L-** HXOL5409-11L-**	21	17	13	24	28	17 (8)	17	81
HXOL5210-10L-** HXOL5410-10L-**	21	17	13	24	28	17 (8)	17	81
HXOL6207-18L-** HXOL6407-18L-**	21	17	13	24	28	20 (9)	20	81
HXOL6208-15L-** HXOL6408-15L-**	21	17	13	24	28	20 (9)	20	81
HXOL6209-13L-** HXOL6409-13L-**	21	17	13	24	28	20 (9)	20	81
HXOL6210-12L-** HXOL6410-12L-**	21	17	13	24	28	20 (9)	20	81
HXOL6211-11L-** HXOL6411-11L-**	21	17	13	24	28	20 (9)	20	81

*******IF SHIPMENT CONTAINS MULTIPLE CARTONS OVER 130" IN GIRTH OR A COMBINED ACTUAL WEIGHT OVER 200 LBS. - LTL FREIGHT IS RECOMMENDED**

QM Quartz Heaters

QM SERIES, QUARTZ HEATERS WITH METAL ELEMENTS (pg A14)								
Model Number	Length	Width	Height	Dim. Wt. Domestic Air	Dim. Wt. International Air & Ground	Actual Weight LBS./(kg)	Shipping Weight Ground	Box Girth
QM.5110-** QM.5210-** ELEMENT ONLY	20 15	9 6	10 7	10 4	11 4	9 (4) 3 (1.5)	9 3	58 41
QM1111-** QM1211-** ELEMENT ONLY	20 15	9 6	10 7	10 4	11 4	10 (4.5) 3 (1.5)	10 3	58 41
QM1117-** QM1217-** ELEMENT ONLY	24 20	11 9	12 10	17 10	20 11	11 (5) 5 (2)	11 5	70 58
QM2217-** QM2417-** ELEMENT ONLY	24 20	11 9	12 10	17 10	20 11	11 (5) 5 (2)	11 5	70 58
QM2223-** QM2423-** ELEMENT ONLY	33 33	13 9	12 6	27 10	32 11	14 (6.5) 6 (2.5)	14 6	83 63
QM3223-** QM3423-** ELEMENT ONLY	33 33	13 9	12 6	27 10	32 11	14 (6.5) 6 (2.5)	14 6	83 63
QM3229-** QM3429-** ELEMENT ONLY	42 33	12 9	12 6	32 10	37 11	17 (8) 8 (3.5)	32 8	90 63
QM3.5229-** QM3.5429-** ELEMENT ONLY	42 33	12 9	12 6	32 10	37 11	17 (8) 8 (3.5)	32 8	90 63

*******IF SHIPMENT CONTAINS MULTIPLE CARTONS OVER 130" IN GIRTH OR A COMBINED ACTUAL WEIGHT OVER 200 LBS. - LTL FREIGHT IS RECOMMENDED**

QM Quartz Heaters (cont.)

QM SERIES, QUARTZ HEATERS WITH METAL ELEMENTS (cont.) (pg A14)								
Model Number	Length	Width	Height	Dim. Wt. Domestic Air	Dim. Wt. International Air & Ground	Actual Weight LBS./(kg)	Shipping Weight Ground	Box Girth
QM4235-** QM4435-** ELEMENT ONLY	42 44	12 9	12 6	32 13	37 15	20 (9) 8 (3.5)	32 8	90 74
QM4241-** QM4441-** ELEMENT ONLY	48 44	13 9	12 6	39 13	46 15	23 (10.5) 9 (4)	39 9	98 74
QM5241-** QM5441-** ELEMENT ONLY	48 44	13 9	12 6	39 13	46 15	23 (10.5) 9 (4)	39 9	98 74
QM5247-** QM5447-** ELEMENT ONLY	55 48	13 13	12 12	45 39	52 46	26 (12) 10 (4.5)	45 39	105 98
QM6247-** QM6447-** ELEMENT ONLY	55 48	13 13	12 12	45 39	52 46	26 (12) 10 (4.5)	45 39	105 98
QM6252-** QM6452-** ELEMENT ONLY	62 55	13 13	12 12	50 45	59 52	29 (13) 12 (5.5)	50 45	112 105
QM8259-** QM8459-** ELEMENT ONLY	67 62	13 13	12 12	54 50	63 59	31 (14) 14 (6.5)	54 50	117 112
QM10271-** QM10471-** ELEMENT ONLY	80 80	13 13	12 12	65 65	76 76	34 (15.5) 20 (9)	65 65	130 ***** 130

*******IF SHIPMENT CONTAINS MULTIPLE CARTONS OVER 130" IN GIRTH OR A COMBINED ACTUAL WEIGHT OVER 200 LBS. - LTL FREIGHT IS RECOMMENDED**

3QM Quartz Heaters

3QM SERIES, TRIPLE QUARTZ HEATERS WITH METAL ELEMENTS (pg A15)								
Model Number	Length	Width	Height	Dim. Wt. Domestic Air	Dim. Wt. International Air & Ground	Actual Weight LBS./(kg)	Shipping Weight Ground	Box Girth
3QM1.5110-** 3QM1.5210-**	21	17	13	24	28	21 (10)	21	81
3QM3111-** 3QM3211-**	21	17	13	24	28	22 (10)	22	81
3QM3117-** 3QM3217-**	33	13	12	27	32	26 (12)	26	83
3QM6217-** 3QM6417-**	33	13	12	27	32	26 (12)	26	83
3QM6223-** 3QM6423-**	33	13	12	30	32	30 (14)	30	83
3QM9223-** 3QM9423-**	33	13	12	30	32	30 (14)	30	83
3QM9229-** 3QM9429-**	44	13	12	36	42	34 (15.5)	36	94
3QM10.5229-** 3QM10.5429-**	44	13	12	36	42	34 (15.5)	36	94
3QM12235-** 3QM1243-**	44	13	12	38	42	38 (17)	38	94
3QM12241-** 3QM12441-**	48	13	12	44	46	44 (20)	44	98
3QM15241-** 3QM15441-**	48	13	12	44	46	44 (20)	44	98
3QM15247-** 3QM15447-**	55	13	12	48	52	48 (22)	48	105
3QM18247-** 3QM18447-**	55	13	12	48	52	48 (22)	48	105
3QM18252-** 3QM18452-**	62	13	12	52	59	52 (24)	52	112
3QM24259-** 3QM24459-**	67	13	12	55	63	55 (25)	55	117
3QM30271-** 3QM30471-**	80	13	12	65	76	65 (30)	65	130 *****

*******IF SHIPMENT CONTAINS MULTIPLE CARTONS OVER 130" IN GIRTH OR A COMBINED ACTUAL WEIGHT OVER 200 LBS. - LTL FREIGHT IS RECOMMENDED**

P, F, S, & T Metal Over The Side Heaters

P, F, S & T SERIES, METAL OVER THE SIDE HEATERS (Single Phase Standard) (pg A20)								
Model Number	Length	Width	Height	Dim. Wt. Domestic Air	Dim. Wt. International Air & Ground	Actual Weight LBS./(kg)	Shipping Weight Ground	Box Girth
*1111-** *1211-**	20	9	10	10	11	8 (4)	8	58
*2217-** *2417-**	33	9	6	10	11	10 (4.5)	10	63
*3223-** *3423-**	33	9	6	12	12	12 (5.5)	12	63
*4229-** *4429-**	33	9	6	13	13	13 (6)	13	63
*5235-** *5435-**	45	9	6	16	16	16 (7.5)	16	75
*6240-** *6440-**	45	9	6	18	18	18 (8)	18	75
*8247-** *8447-**	55	13	12	45	52	23 (10.5)	45	105
*9254-** *9454-**	62	13	12	50	59	24 (11)	50	112
*10259-** *10459-**	67	13	12	54	63	25 (11.5)	54	117
*12268-** *12468-**	80	13	12	65	76	29 (13)	65	130 *****

*******IF SHIPMENT CONTAINS MULTIPLE CARTONS OVER 130" IN GIRTH OR A COMBINED ACTUAL WEIGHT OVER 200 LBS. - LTL FREIGHT IS RECOMMENDED**

3P, 3F, 3S & 3T Metal Over The Side Heaters

3P, 3F, 3S, & 3T SERIES, TRIPLE METAL OVER THE SIDE HEATERS (pg A21)								
Model Number	Length	Width	Height	Dim. Wt. Domestic Air	Dim. Wt. International Air & Ground	Actual Weight LBS./(kg)	Shipping Weight Ground	Box Girth
3*3211-** 3*3411-**	21	17	13	24	28	21 (9.5)	24	81
3*6217-** 3*6417-**	33	13	12	30	32	30 (14)	30	83
3*9223-** 3*9423-**	33	13	12	35	35	35 (16)	35	83
3*12229-** 3*12429-**	44	13	12	39	42	39 (18)	39	94
3*15235-** 3*15435-**	44	13	12	48	48	48 (22)	48	94
3*18240-** 3*18440-**	48	13	12	51	51	51 (23)	51	98
3*24247-* 3*24447-**	55	13	12	68	68	68 (31)	68	105
3*27254-** 3*27454-**	62	13	12	71	71	71 (32.5)	71	112
3*30259-** 3*30459-**	67	13	12	75	75	75 (34)	75	117
3*36268-** 3*36468-**	80	13	12	88	88	88 (40)	88	130 ****

*******IF SHIPMENT CONTAINS MULTIPLE CARTONS OVER 130" IN GIRTH OR A COMBINED ACTUAL WEIGHT OVER 200 LBS. - LTL FREIGHT IS RECOMMENDED**

D Metal Over The Side Heaters

D SERIES, DERATED METAL OVER THE SIDE HEATERS (Single Phase Standard) (pg A22)								
Model Number	Length	Width	Height	Dim. Wt. Domestic Air	Dim. Wt. International Air & Ground	Actual Weight LBS./ (kg)	Shipping Weight Ground	Box Girth
D*.5111-** D*.5211-**	20	9	10	10	11	8 (4)	8	58
D*1217-** D*1417-**	33	9	6	10	11	10 (4.5)	10	63
D*1.5223-** D*1.5423-**	33	9	6	12	12	12 (5.5)	12	63
D*2229-** D*2429-**	33	9	6	13	13	13 (6)	13	63
D*2.5235-** D*2.5435-**	45	9	6	16	16	16 (7.5)	16	75
D*3240-** D*3440-**	45	9	6	18	18	18 (8)	18	75
D*4247-** D*4447-**	55	13	12	45	52	23 (10.5)	45	105
D*4.5254-** D*4.5454-**	62	13	12	50	59	24 (11)	50	112
D*5259-** D*5459-**	67	13	12	54	63	25 (11.5)	54	117
D*6268-** D*6468-**	80	13	12	65	76	29 (13)	65	130 *****

*******IF SHIPMENT CONTAINS MULTIPLE CARTONS OVER 130" IN GIRTH OR A COMBINED ACTUAL WEIGHT OVER 200 LBS. - LTL FREIGHT IS RECOMMENDED**

D3 Metal Over The Side Heaters

D3 SERIES, DERATED TRIPLE METAL OVER THE SIDE HEATERS (pg A23)								
Model Number	Length	Width	Height	Dim. Wt. Domestic Air	Dim. Wt. International Air & Ground	Actual Weight LBS./(kg)	Shipping Weight Ground	Box Girth
D3*1.5111-** D3*1.5211-**	21	17	13	24	28	21 (9.5)	24	81
D3*3217-** D3*3417-**	33	13	12	30	32	30 (14)	30	83
D3*4.5223-** D3*4.5423-**	33	13	12	35	35	35 (16)	35	83
D3*6229-** D3*6429-**	44	13	12	39	42	39 (18)	39	94
D3*7.5235-** D3*7.5435-**	44	13	12	48	48	48 (22)	48	94
D3*9240-** D3*9440-**	48	13	12	51	51	51 (23)	51	98
D3*12247-** D3*12447-**	55	13	12	68	68	68 (31)	68	105
D3*13.5254-** D3*13.5454-**	62	13	12	71	71	71 (32.5)	71	112
D3P15259-** D3915459-**	67	13	12	75	75	75 (34)	75	117
D3P18268-** D3P18468-**	80	13	12	88	88	88 (40)	88	130 ****

*******IF SHIPMENT CONTAINS MULTIPLE CARTONS OVER 130" IN GIRTH OR A COMBINED ACTUAL WEIGHT OVER 200 LBS. - LTL FREIGHT IS RECOMMENDED**

L Metal L-Shaped Heaters

L SERIES, METAL L-SHAPED HEATERS (Single Phase Standard) (pg A24)									
Model Number	Length	Width	Height	Dim. Wt. Domestic Air	Dim. Wt. International Air & Ground	Actual Weight LBS./(kg)	Shipping Weight Ground	Add'l Shipping Charges	Box Girth
L*1113-R*-** L*1213-R*-**	24	12	21	32	37	12 (5.5)	32		90
L*2117-R*-** L*2217-R*-** L*2417-R*-**	33	14	24	58	67	16 (7.5)	58		109
L*3222-R*-** L*3422-R*-**	33	14	28	67	78	20 (9)	67		117
L*4226-R*-** L*4426-R*-**	42	12	28	73	86	21 (9.5)	73		122
L*5231-R*-** L*5431-R*-**	42	13	42	119	139	24 (11)	119	\$40	152 *****
L*6236-R*-** L*6436-R*-**	48	14	56	194	227	30 (14)	194	\$40	180 *****
L*8244-R*-** L*8444-R*-**	55	14	56	223	260	34 (15.5)	223	Too large for UPS	194 *****
L*9250-R*-** L*9450-R*-**	62	14	56	251	293	36 (16.5)	251	Too large for UPS	202 *****
L*10255-R*-** L*10455-R*-**	67	14	56	271	317	39 (18)	271	Too large for UPS	207 *****
L*12264-R*-** L*12464-R*-**	80	14	56	324	378	46 (21)	324	Too large for UPS	220 *****

*****IF SHIPMENT CONTAINS MULTIPLE CARTONS OVER 130" IN GIRTH OR A COMBINED ACTUAL WEIGHT OVER 200 LBS. - LTL FREIGHT IS RECOMMENDED

TOO LARGE FOR UPS
 L-SHAPE BOX

3L Metal L-Shaped Heaters

3L SERIES, TRIPLE METAL L-SHAPED HEATERS (Three Phase Standard) (pg A25)									
Model Number	Length	Width	Height	Dim. Wt. Domestic Air	Dim. Wt. International Air & Ground	Actual Weight LBS./(kg)	Shipping Weight Ground	Add'l Shipping Charges	Box Girth
3L*3213-R*-** 3L*3413-R*-**	24	12	21	32	37	30 (14)	30		90
3L*6217R*-** 3L*6417-R*-**	44	14	24	77	90	33 (15)	77		120
3L*9222-R*-** 3L*9422-R*-**	48	14	30	104	122	40 (18)	104	\$40	136 *****
3L*12226-R*-** 3L*12426-R*-**	44	14	44	140	164	44 (20)	140	\$40	160 *****
3L*15231-R*-** 3L*15431-R*-**	44	14	44	140	164	49 (22.5)	140	\$40	160 *****
3L*18236-R*-** 3L*18436-R*-**	80	14	28	191	191	59 (27)	191	\$40	164 *****
3L*24244-R*-** 3L*24444-R*-**	55	14	55	219	256	68 (31)	219	Too large for UPS	193 *****
3L*27250-R*-** 3L*27450-R*-**	62	14	55	247	288	75 (34)	247	Too large for UPS	200 *****
3L*30255-R*-** 3L*30455-R*-**	67	14	55	266	311	81 (37)	266	Too large for UPS	205 *****
3L*36264-R*-** 3L*36464-R*-**	80	14	55	318	372	93 (42.5)	318	Too large for UPS	218 *****

*****IF SHIPMENT CONTAINS MULTIPLE CARTONS OVER 130" IN GIRTH OR A COMBINED ACTUAL WEIGHT OVER 200 LBS. - LTL FREIGHT IS RECOMMENDED

TOO LARGE FOR UPS
 L-SHAPE BOX

3LV Metal L-Shaped Heaters

3LV SERIES, VERTICAL STACK TRIPLE METAL L-SHAPED HEATERS (Three Phase Standard) (pg A28)									
Model Number	Length	Width	Height	Dim. Wt. Domestic Air	Dim. Wt. International Air & Ground	Actual Weight LBS./(kg)	Shipping Weight Ground	Add'l Shipping Charges	Box Girth
3LV*3213-R*-** 3LV*3413-R*-**	24	12	21	32	37	30 (14)	32		90
3LV*6217-R*-** 3LV*6417-R*-**	33	14	24	58	67	33 (15)	58		109
3LV*9222-R*-** 3LV*9422-R*-**	48	14	30	104	122	40 (18)	104	\$40	136 *****
3LV*12226-R*-** 3LV*12426-R*-**	44	14	44	140	164	44 (20)	140	\$40	160 *****
3LV*15231-R*-** 3LV*15431-R*-**	44	14	44	140	164	49 (22.5)	140	\$40	160 *****
3LV*18236-R*-** 3LV*18436-R*-**	48	14	55	191	223	59 (27)	191	\$40	179 *****
3LV*24244-R*-** 3LV*24444-R*-**	55	14	55	219	256	68 (31)	219	Too large for UPS	193 *****
3LV*27250-R*-** 3LV*27450-R*-**	62	14	55	247	288	75 (34)	247	Too large for UPS	200 *****
3LV*30255-R*-** 3LV*30455-R*-**	67	14	55	266	311	81 (37)	266	Too large for UPS	205 *****
3LV*36264-R*-** 3LV*36464-R*-**	80	14	55	318	372	93 (42.5)	318	Too large for UPS	218 *****

*****IF SHIPMENT CONTAINS MULTIPLE CARTONS OVER 130" IN GIRTH OR A COMBINED ACTUAL WEIGHT OVER 200 LBS. - LTL FREIGHT IS RECOMMENDED

TOO LARGE FOR UPS
 L-SHAPE BOX

DL Metal L-Shaped Heaters

DL SERIES, DERATED METAL L-SHAPED HEATERS (Single Phase Standard) (pg A26)									
Model Number	Length	Width	Height	Dim. Wt. Domestic Air	Dim. Wt. International Air & Ground	Actual Weight LBS./(kg)	Shipping Weight Ground	Add'l Shipping Charge	Box Girth
DL*.5113-R*-.** DL*.5213-R*-.**	24	12	21	32	37	12 (5.5)	32		90
DL*1117-R*-.** DL*1217-R*-.**	33	14	24	58	67	16 (7.5)	58		109
DL*1.5122-R*-.** DL*1.5222-R*-.** DL*1.5422-R*-.**	33	14	28	67	78	20 (9)	67		117
DL*2226-R*-.** DL*2426-R*-.**	42	12	28	73	86	21 (9.5)	73		122
DL*2.5231-R*-.** DL*2.5431-R*-.**	42	13	42	119	139	24 (11)	119	\$40	152 *****
DL*3236-R*-.** DL*3436-R*-.**	48	14	56	194	227	30 (14)	194	\$40	180 *****
DL*4244-R*-.** DL*444-R*-.**	55	14	56	223	260	34 (15.5)	223	Too large for UPS	194 *****
DL*4.5250-R*-.** DL*4.5450-R*-.**	62	14	56	251	293	36 (16.5)	251	Too large for UPS	202 *****
DL*5255-R*-.** DL*5455-R*-.**	67	14	56	271	317	39 (18)	271	Too large for UPS	207 *****
DL*6264-R*-.** DL*6464-R*-.**	80	14	56	324	378	46 (21)	324	Too large for UPS	220 *****

*****IF SHIPMENT CONTAINS MULTIPLE CARTONS OVER 130" IN GIRTH OR A COMBINED ACTUAL WEIGHT OVER 200 LBS. - LTL FREIGHT IS RECOMMENDED

**TOO LARGE FOR UPS
 L-SHAPE BOX**

D3L Metal L-Shaped Heaters

D3L SERIES DERATED TRIPLE METAL L-SHAPED HEATERS (Three Phase Standard) (pg A27)									
Model Number	Length	Width	Height	Dim. Wt. Domestic Air	Dim. Wt. International Air & Ground	Actual Weight LBS./(kg)	Shipping Weight Ground	Add'l Shipping Charges	Box Girth
D3L*1.5113-R* D3L*1.5213-R*	24	12	21	32	37	30 (14)	32		90
D3L*3217-R* D3L*3417-R*	44	14	24	77	90	33 (15)	77		120
D3L*4.5222-R* D3L*4.5422-R*	48	14	30	104	122	40 (18)	104	\$40	136 *****
D3L*6226-R* D3L*6426-R*	44	14	44	140	164	44 (20)	140	\$40	160 *****
D3L*7.5231-R* D3L*7.5431-R*	44	14	44	140	164	49 (22.5)	140	\$40	160 *****
D3L*9236-R* D3L*9436-R*	48	14	55	191	223	59 (27)	191	\$40	179 *****
D3L*12244-R* D3L*12444-R*	55	14	55	219	256	68 (31)	219	Too large for UPS	193 *****
D3L*13.5250-R* D3L*13.5450-R*	62	14	55	247	288	75 (34)	247	Too large for UPS	200 *****
D3L*15255-R* D3L*15455-R*	67	14	55	266	311	81 (37)	266	Too large for UPS	205 *****
D3L*18264-R* D3L*18464-R*	80	14	55	318	372	93 (42.5)	318	Too large for UPS	218 *****

*******IF SHIPMENT CONTAINS MULTIPLE CARTONS OVER 130" IN GIRTH OR A COMBINED ACTUAL WEIGHT OVER 200 LBS. - LTL FREIGHT IS RECOMMENDED**

TOO LARGE FOR UPS
L-SHAPE BOX

Deep Tank Metal & Triple Metal Heaters

DEEP TANK METAL HEATERS (Single Phase Standard) (pg A30)									
Model Number	Length	Width	Height	Dim. Wt. Domestic Air	Dim. Wt. International Air & Ground	Actual Weight LBS./(kg)	Shipping Weight Ground	Add'l Shipping Charges	Box Girth
*12296-** *12499-**	110	15	15	128	150	37 (17)	128	\$40	170 *****
*122120-** *124120-**	134	15	15	156	182	45 (20)	156	Too large for UPS	194 *****
*122144-** *124144-**	160	15	15	186	217	53 (24)	186	Too large for UPS	220 *****
*15296-** *15496-**	110	15	15	128	150	37 (17)	128	\$40	170 *****
*152120-** *154120-**	134	15	15	156	182	45 (20)	156	Too large for UPS	194 *****
*152144-** *154144-**	160	15	15	186	217	53 (24)	186	Too large for UPS	220 *****
*18296-** *18496-**	110	15	15	128	150	37 (17)	128	\$40	170 *****
*182120-** *184120-**	134	15	15	156	182	45 (20)	156	Too large for UPS	194 *****
*182144-** *184144-**	160	15	15	186	217	53 (24)	186	Too large for UPS	220 *****

3V SERIES, TRIPLE METAL DEEP TANK HEATERS (Three Phase Standard) (pg A31)									
Model Number	Length	Width	Height	Dim. Wt. Domestic Air	Dim. Wt. International Air & Ground	Actual Weight LBS./(kg)	Shipping Weight Ground	Add'l Shipping Charges	Box Girth
3V*18236-** 3V*18436-**	55	13	12	70	70	70 (32)	70		105
3V*24244-** 3V*24444-**	62	13	12	75	75	75 (34)	75		112
3V*27250-** 3V*27450-**	67	13	12	80	80	80 (36)	80		117
3V*30255-** 3V*30455-**	80	13	12	87	87	87 (40)	87		130 *****
3V*36264-** 3V*36464-**	88	14	14	100	104	100 (46)	100	Too large for UPS	144 *****
3V*45272-** 3V*45472-**	96	14	14	120	120	120 (55)	120	Too large for UPS	152 *****
3V*48276-** 3V*48476-**	96	14	14	125	125	125 (57)	125	Too large for UPS	152 *****
3V*54284-** 3V*54484-**	110	14	14	140	140	140 (64)	140	Too large for UPS	166 *****

*****IF SHIPMENT CONTAINS MULTIPLE CARTONS OVER 130" IN GIRTH OR A COMBINED ACTUAL WEIGHT OVER 200 LBS. - LTL FREIGHT IS RECOMMENDED

TOO LARGE FOR UPS

3HS, 6HS & 9HS Stainless Steel Heaters

3HS SERIES, 3 ELEMENT 316 STAINLESS STEEL HEATERS (Three Phase Standard) (pg A17)								
Model Number	Length	Width	Height	Dim. Wt. Domestic Air	Dim. Wt. International Air & Ground	Actual Weight LBS./(kg)	Shipping Weight Ground	Box Girth
3HS3217-** 3HS3417-**	24	11	12	17	20	9 (4)	9	70
3HS4.5223-** 3HS4.5423-**	33	13	12	27	32	10 (4.5)	10	83
3HS7.5229-** 3HS7.5429-**	42	12	12	32	37	12 (5.5)	32	90
3HS10.5234-** 3HS10.5434-**	42	12	12	32	37	14 (6.5)	32	90

6HS SERIES, 6 ELEMENT 316 STAINLESS STEEL HEATERS (Three Phase Standard) (pg A18)								
Model Number	Length	Width	Height	Dim. Wt. Domestic Air	Dim. Wt. International Air & Ground	Actual Weight LBS./(kg)	Shipping Weight Ground	Box Girth
6HS6217-** 6HS6417-**	24	11	12	17	20	15 (7)	15	70
6HS9223-** 6HS9423-**	33	13	12	27	32	20 (9)	20	83
6HS15229-** 6HS15429-**	42	12	12	32	37	24 (11)	32	90
6HS21234-** 6HS21434-**	42	12	12	32	37	27 (12.5)	32	90

9HS SERIES, 9 ELEMENT 316 STAINLESS STEEL HEATERS (Three Phase Standard) (pg A19)								
Model Number	Length	Width	Height	Dim. Wt. Domestic Air	Dim. Wt. International Air & Ground	Actual Weight LBS./(kg)	Shipping Weight Ground	Box Girth
9HS9217-** 9HS9417-**	33	13	12	27	32	25 (11.5)	25	83
9HS13.5223-** 9HS13.5423-**	33	13	12	28	32	28 (13)	28	83
9HS22.5229-** 9HS22.5429-**	44	13	12	36	42	33 (15)	36	94
9HS31.5234-** 9HS31.5434-**	44	13	12	38	42	38 (17.5)	38	94

*******IF SHIPMENT CONTAINS MULTIPLE CARTONS OVER 130" IN GIRTH OR A COMBINED ACTUAL WEIGHT OVER 200 LBS. - LTL FREIGHT IS RECOMMENDED**

DAS Phospate & V Varipower Heaters

DAS SERIES, OVER THE SIDE 316 STAINLESS STEEL PHOSPHATE HEATERS (pg A32)								
Model Number	Length	Width	Height	Dim. Wt. Domestic Air	Dim. Wt. International Air & Ground	Actual Weight LBS./ (kg)	Shipping Weight Ground	Box Girth
DAS1111-PIM DAS1211-PIM	20	9	10	17	17	17 (8)	17	58
DAS2217-PIM DAS2417-PIM	24	11	12	20	20	20 (9)	20	70
DAS3223-PIM DAS3423-PIM	33	13	12	27	32	24 (11)	24	83
DAS3.5229-PIM DAS3.5429-PIM	42	12	12	32	37	30 (14)	32	90
DAS4235-PIM DAS4435-PIM	42	12	12	36	37	36 (16)	36	90
DAS5241-PIM DAS5441-PIM	48	13	12	42	46	42 (19)	42	98
DAS6247-PIM DAS6447-PIM	55	13	12	48	52	48 (22)	48	105
DAS8259-PIM DAS8459-PIM	67	13	12	58	63	58 (27)	58	117
DAS10271-PIM DAS10471-PIM	80	13	12	65	76	64 (30)	65	130 *****

V SERIES, VARIPOWER HEATERS (1/2" Dia.) (pg A34)								
Model Number	Length	Width	Height	Dim. Wt. Domestic Air	Dim. Wt. International Air & Ground	Actual Weight LBS./ (kg)	Shipping Weight Ground	Box Girth
V*.1107 V*.1207	10	10	7	4	5	2 (1)	2	44
V*.3111 V*.3211	10	10	7	4	5	2 (1)	2	44
V*.5111 V*.5211	10	10	7	4	5	2 (1)	2	44
V*1111 V*1211	10	10	7	4	5	2 (1)	2	44

*******IF SHIPMENT CONTAINS MULTIPLE CARTONS OVER 130" IN GIRTH OR A COMBINED ACTUAL WEIGHT OVER 200 LBS. - LTL FREIGHT IS RECOMMENDED**

QMB & B Small Tank Heaters

QMB SERIES, SMALL TANK QUARTZ HEATERS (1-3/8" Dia.) (pg A16)								
Model Number	Length	Width	Height	Dim. Wt. Domestic Air	Dim. Wt. International Air & Ground	Actual Weight LBS./ (kg)	Shipping Weight Ground	Box Girth
QMB.5111C-** QMB.5211C-**	20	9	10	10	11	5 (2)	5	58
QMB1111C-** QMB1211C-**	20	9	10	10	11	6 (2.5)	6	58
QMB1.5117C-** QMB1.5217C-**	21	11	12	15	17	9 (4)	9	67

B SERIES, SMALL TANK METAL HEATERS (1-1/4" Dia.) (pg A33)								
Model Number	Length	Width	Height	Dim. Wt. Domestic Air	Dim. Wt. International Air & Ground	Actual Weight LBS./ (kg)	Shipping Weight Ground	Box Girth
*B.5110-** *B.5210-**	20	9	10	10	11	5 (2)	5	58
*B1114-** *B1214-**	20	9	10	10	11	6 (2.5)	6	58
*B1.5117-** *B1.5217-**	24	11	12	17	20	8 (3.5)	8	70
*B2123-** *B2223-**	33	13	12	27	32	9 (4)	9	83

*******IF SHIPMENT CONTAINS MULTIPLE CARTONS OVER 130" IN GIRTH OR A COMBINED ACTUAL WEIGHT OVER 200 LBS. - LTL FREIGHT IS RECOMMENDED**

Tytan Heaters

TYTAN WATER HEATERS (pg A35)								
Model Number	Length	Width	Height	Dim. Wt. Domestic Air	Dim. Wt. International Air & Ground	Actual Weight LBS./ (kg)	Shipping Weight Ground	Box Girth
TY-012-240 TY-012-480	48	48	29	345	403	125 (57)	345	202 *****
TY-018-240 TY-018-480	48	48	29	345	403	125 (57)	345	202 *****
TY-024-240 TY-024-480	48	48	29	345	403	125 (57)	345	202 *****
TY-048-240	48	48	29	345	403	175 (80)	345	202 *****
TY-048-480	48	48	29	345	403	175 (80)	345	202 *****
TY-072-240	48	48	29	345	403	225 (102)	345	202 *****
TY-072-480	48	48	29	345	403	225 (102)	345	202 *****
TY-096-480	40	34	80	561	656	400 (182)	561	268 *****
TY-120-480	40	34	80	561	656	450 (204)	561	268 *****
TY-1440-480	40	34	80	561	656	500 (227)	561	268 *****

ALL OF THE ABOVE ARE WOOD CRATES

*******IF SHIPMENT CONTAINS MULTIPLE CARTONS OVER 130" IN GIRTH OR A COMBINED ACTUAL WEIGHT OVER 200 LBS. - LTL FREIGHT IS RECOMMENDED**

TOO LARGE FOR UPS

T & 2T Screw Plug Heaters

T SERIES, 2" TUBULAR SCREW PLUG HEATERS (Single Phase Standard) (pg A36)								
Model Number	Length	Width	Height	Dim. Wt. Domestic Air	Dim. Wt. International Air & Ground	Actual Weight LBS./ (kg)	Shipping Weight Ground	Box Girth
*T1110 *T1210	20	9	10	11	11	11 (5)	11	58
*T2114 *T2214 *T2414	20	9	10	14	14	14 (6.5)	14	58
*T3219 *T3419	33	9	6	16	16	16 (7.5)	16	63
*T4223 *T4423	33	9	6	20	20	20 (9)	20	63
*T6233 *T6433	45	9	6	26	26	26 (12)	26	75
*T8240 *T8440	45	9	6	29	29	29 (13.5)	29	75
*T9247 *T9447	55	13	12	45	52	32 (14.5)	45	105
*T12261 *T12461	67	13	12	54	63	37 (17)	54	117

2T SERIES, 2" 316 STAINLESS SCREW PLUG HEATERS (pg A37)								
Model Number	Length	Width	Height	Dim. Wt. Domestic Air	Dim. Wt. International Air & Ground	Actual Weight LBS./ (kg)	Shipping Weight Ground	Box Girth
2T2208 2T2408	20	9	10	10	11	6 (3)	6	58
2T3212 2T3412	20	9	10	10	11	6 (3)	6	58
2T4218 2T4418	33	9	6	10	11	7 (3.5)	7	63
2T6225 2T6425	33	9	6	10	11	8 (4)	8	63
2T8228 2T8428	33	9	6	10	11	10 (4.5)	10	63
2T10241 2T10441	45	9	6	13	15	11 (5)	11	75
2T12248 2T12448	55	13	12	45	52	13 (6)	45	105
2T15254 2T15454	62	13	12	50	59	15 (7)	50	112

*******IF SHIPMENT CONTAINS MULTIPLE CARTONS OVER 130" IN GIRTH OR A COMBINED ACTUAL WEIGHT OVER 200 LBS. - LTL FREIGHT IS RECOMMENDED**

5T, T2T & T5T Screw Plug Heaters

5T SERIES, 2-1/2" 316 STAINLESS SCREW PLUG HEATERS (pg A38)								
Model Number	Length	Width	Height	Dim. Wt. Domestic Air	Dim. Wt. International Air & Ground	Actual Weight LBS./(kg)	Shipping Weight Ground	Box Girth
5T4.5212 5T4.5412	20	9	10	10	11	9 (4)	9	58
5T6217 5T6417	33	9	6	10	11	10 (4.5)	10	63
5T9225 5T9425	33	9	6	11	11	11 (5)	11	63
5T12232 5T12432	45	9	6	13	15	13 (6)	13	75
5T15240 5T15440	45	9	6	14	15	14 (6.5)	14	75
5T18248 5T18448	55	13	12	45	52	18 (8)	45	105

T2T SERIES, 2" TITANIUM SCREW PLUG HEATERS (pg A37)								
Model Number	Length	Width	Height	Dim. Wt. Domestic Air	Dim. Wt. International Air & Ground	Actual Weight LBS./(kg)	Shipping Weight Ground	Box Girth
T2T2208 T2T2408	20	9	10	10	11	4 (2)	4	58
T2T4213 T2T4413	20	9	10	10	11	6 (3)	6	58
T2T6223 T2T6423	33	9	6	10	11	7 (3.5)	7	63
T2T8228 T2T8428	33	9	6	10	11	8 (4)	8	63
T2T12238 T2T12438	45	9	6	13	15	10 (4.5)	10	75

T5T SERIES, 2 1/2" TITANIUM SCREW PLUG HEATERS (pg A38)								
Model Number	Length	Width	Height	Dim. Wt. Domestic Air	Dim. Wt. International Air & Ground	Actual Weight LBS./(kg)	Shipping Weight Ground	Box Girth
T5T3208 T5T3408	20	9	10	10	11	5 (2.5)	5	58
T5T6213 T5T6413	20	9	10	10	11	6 (3)	6	58
T5T9223 T5T9423	33	9	6	10	11	7 (3.5)	7	63
T5T12228 T5T12428	33	9	6	10	11	8 (4)	8	63
T5T18238 T5T18438	45	9	6	13	15	13 (6)	13	75

*******IF SHIPMENT CONTAINS MULTIPLE CARTONS OVER 130" IN GIRTH OR A COMBINED ACTUAL WEIGHT OVER 200 LBS. - LTL FREIGHT IS RECOMMENDED**

VST, VXT, TB & HXT Screw Plug Heaters

V*T SERIES, 1/2" VARIPOWER SCREW PLUG HEATERS (pg A34)								
Model Number	Length	Width	Height	Dim. Wt. Domestic Air	Dim. Wt. International Air & Ground	Actual Weight LBS./ (kg)	Shipping Weight Ground	Box Girth
V*T.1107 V*T.1207	13	6	5	3	3	1 (.5)	1	35
V*T.2110 V*T.2210	13	6	5	3	3	1 (.5)	1	35

TB SERIES, 1-1/4" SMALL TANK SCREW PLUG HEATERS (pg A39)								
Model Number	Length	Width	Height	Dim. Wt. Domestic Air	Dim. Wt. International Air & Ground	Actual Weight LBS./ (kg)	Shipping Weight Ground	Box Girth
*TB.5108 *TB.5208	13	6	5	8	8	8 (4)	8	35
*TB1110 *TB1210	13	6	5	10	10	10 (4.5)	10	35
*TB1.5114 *TB1.5214	20	9	10	14	14	14 (6.5)	14	58
*TB2117 *TB2217	20	9	10	17	17	17 (8)	17	58

HXT SERIES, FLUOROPOLYMER (PTFE) SCREW PLUG HEATERS (pg A40)								
Model Number	Length	Width	Height	Dim. Wt. Domestic Air	Dim. Wt. International Air & Ground	Actual Weight LBS./ (kg)	Shipping Weight Ground	Box Girth
HXT1109 HXT1209	20	9	10	10	11	9 (4)	9	58
HXT2214 HXT2414	20	9	10	12	12	12 (5.5)	12	58
HXT3219 HXT3419	24	11	12	17	20	15 (7)	15	70
HXT4226 HXT4426	33	13	12	27	32	17 (8)	17	83
HXT5230 HXT5430	33	13	12	27	32	20 (9)	17	83
HXT6234 HXT6434	42	12	12	32	37	23 (11)	32	90

*******IF SHIPMENT CONTAINS MULTIPLE CARTONS OVER 130" IN GIRTH OR A COMBINED ACTUAL WEIGHT OVER 200 LBS. - LTL FREIGHT IS RECOMMENDED**

3FLX & 6FLX Flanged Fluoropolymer Heaters

3FLX SERIES, 3" 150# FLANGED FLUOROPOLYMER (PTFE) HEATERS (Single Phase Only) (pg A42)								
Model Number	Length	Width	Height	Dim. Wt. Domestic Air	Dim. Wt. International Air & Ground	Actual Weight LBS./ (kg)	Shipping Weight Ground	Box Girth
3FLX1111- 3FLX1211-*	20	9	10	20	20	20 (9)	20	58
3FLX2216- 3FLX2416-*	20	9	10	23	23	23 (11)	23	58
3FLX3221- 3FLX3421-*	33	13	12	27	32	26 (12)	26	83
3FLX4228- 3FLX4428-*	33	13	12	29	32	29 (13)	29	83
3FLX5232- 3FLX5432-*	42	12	12	32	37	32 (15)	32	90
3FLX6235- 3FLX6435-*	42	12	12	35	37	35 (16)	35	90

6FLX SERIES, 6" 150# FLANGED FLUOROPOLYMER (PTFE) HEATERS (Three Phase Standard) (pg A42)								
Model Number	Length	Width	Height	Dim. Wt. Domestic Air	Dim. Wt. International Air & Ground	Actual Weight LBS./ (kg)	Shipping Weight Ground	Box Girth
6FLX3211- 6FLX3411-*	33	13	12	42	42	42 (19)	42	83
6FLX6216- 6FLX6416-*	33	13	12	51	51	51 (23)	51	83
6FLX9221- 6FLX9421-*	33	13	12	60	60	60 (27)	60	83
6FLX12228- 6FLX12428-*	44	13	12	66	66	66 (30)	66	94
6FLX15232- 6FLX15432-*	44	13	12	75	75	75 (34)	75	94
6FLX18235- 6FLX18435-*	44	13	12	84	84	84 (38)	84	94

*******IF SHIPMENT CONTAINS MULTIPLE CARTONS OVER 130" IN GIRTH OR A COMBINED ACTUAL WEIGHT OVER 200 LBS. - LTL FREIGHT IS RECOMMENDED**

3FLS & 5FLS Flanged Metal Heaters

3FLS SERIES METAL HEATERS, 3" 150 LB. 316 STAINLESS FLANGE (3 ELEMENTS) (pg A41)								
Model Number	Length	Width	Height	Dim. Wt. Domestic Air	Dim. Wt. International Air & Ground	Actual Weight LBS./(kg)	Shipping Weight Ground	Box Girth
3FLS3209-* 3FLS3409-*	20	9	10	14	14	14 (6.5)	14	58
3FLS4.5213-* 3FLS4.5413-*	20	9	10	15	15	15 (7)	15	58
3FLS6219-* 3FLS6419-*	24	11	12	17	20	16 (7.5)	16	70
3FLS9226-* 3FLS9426-*	33	13	12	27	32	17 (7.5)	17	83
3FLS12233-* 3FLS12433-*	42	12	12	32	37	18 (8)	32	90
3FLS15241-* 3FLS15441-*	48	13	12	39	46	20 (9)	39	98
3FLS18249-* 3FLS18449-*	55	13	12	45	52	21 (9.5)	45	105

5FLS SERIES METAL HEATERS, 5" 150 LB. 316 STAINLESS FLANGE (6 ELEMENTS) (pg A41)								
Model Number	Length	Width	Height	Dim. Wt. Domestic Air	Dim. Wt. International Air & Ground	Actual Weight LBS./(kg)	Shipping Weight Ground	Box Girth
5FLS6209-* 5FLS6409-*	20	9	10	25	25	25 (11.5)	25	58
5FLS9213-* 5FLS9413-*	20	9	10	28	28	28 (13)	28	58
5FLS12219-* 5FLS12419-*	33	13	12	30	32	30 (14)	30	83
5FLS18226-* 5FLS18426-*	33	13	12	33	33	33 (15)	33	83
5FLS24233-* 5FLS24433-*	44	13	12	37	42	37 (17)	37	94
5FLS30241-* 5FLS30441-*	48	13	12	40	46	40 (18)	40	98
5FLS36249-* 5FLS36449-*	55	13	12	45	52	43 (19.5)	45	105

*******IF SHIPMENT CONTAINS MULTIPLE CARTONS OVER 130" IN GIRTH OR A COMBINED ACTUAL WEIGHT OVER 200 LBS. - LTL FREIGHT IS RECOMMENDED**

6FLS & 8FLS Flanged Metal Heaters

6FLS SERIES METAL HEATERS, 6" 150 LB. 316 STAINLESS FLANGE (12 ELEMENTS) (pg A41)								
Model Number	Length	Width	Height	Dim. Wt. Domestic Air	Dim. Wt. International Air & Ground	Actual Weight LBS./ (kg)	Shipping Weight Ground	Box Girth
6FLS12209-* 6FLS12409-*	20	9	10	48	48	48 (22)	48	58
6FLS18213-* 6FLS18413-*	20	9	10	54	54	54 (24.5)	54	58
6FLS24219-* 6FLS24419-*	24	11	12	60	60	60 (27)	60	70
6FLS36226-* 6FLS36426-*	33	13	12	67	67	67 (30.5)	67	83
6FLS48233-* 6FLS48433-*	42	12	12	76	76	76 (34.5)	76	90
6FLS60241-* 6FLS60441-*	48	13	12	84	84	84 (38)	84	98
6FLS72249-* 6FLS72449-*	55	13	12	111	111	111 (50.5)	111	105

8FLS SERIES METAL HEATERS, 8" 150 LB. 316 STAINLESS FLANGE (18 ELEMENTS) (pg A41)								
Model Number	Length	Width	Height	Dim. Wt. Domestic Air	Dim. Wt. International Air & Ground	Actual Weight LBS./ (kg)	Shipping Weight Ground	Box Girth
8FLS18209-* 8FLS18409-*	21	17	12	84	84	84 (38)	84	79
8FLS27213-* 8FLS27413-*	21	17	12	92	92	92 (42)	92	79
8FLS36219-* 8FLS36419-*	33	13	12	100	100	100 (45.5)	100	83
8FLS54226-* 8FLS54426-*	33	13	12	110	110	110 (50)	110	83
8FLS72233-* 8FLS72433-*	44	13	12	120	120	120 (54.5)	120	94
8FLS90241-* 8FLS80441-*	48	13	12	126	126	126 (57)	126	98
8FLS108249-* 8FLS108449-*	55	13	12	130	130	130 (59)	130	105

Should consider crating any over 80#

*******IF SHIPMENT CONTAINS MULTIPLE CARTONS OVER 130" IN GIRTH OR A COMBINED ACTUAL WEIGHT OVER 200 LBS. - LTL FREIGHT IS RECOMMENDED**

10FLS & 12FLS Flanged Metal Heaters

10FLS SERIES METAL HEATERS, 10" 150 LB. 316 STAINLESS FLANGE (27 ELEMENTS) (pg A41)									
Model Number	Length	Width	Height	Dim. Wt. Domestic Air	Dim. Wt. International Air & Ground	Actual Weight LBS./(kg)	Shipping Weight Ground	Add'l Shipping Charges	Box Girth
10FLS27209-* 10FLS27409-*	21	17	12	91	91	91 (41.5)	91		79
10FLS40.5213-* 10FLS40.5413-*	21	17	12	99	99	99 (45)	99		79
10FLS54219-* 10FLS54419-*	33	13	12	108	108	108 (49)	108		83
10FLS81226-* 10FLS81426-*	33	13	12	120	120	120 (54.5)	120		83
10FLS108233-* 10FLS108433-*	44	13	12	135	135	135 (61)	135		94
10FLS135241-* 10FLS15441-*	48	13	12	165	165	165 (75)	165	Too heavy for UPS	98
10FLS162249-* 10FLS162449-*	55	13	12	200	200	200 (91)	200	Too heavy for UPS	105

12FLS SERIES METAL HEATERS, 12" 150 LB. 316 STAINLESS FLANGE (36 ELEMENTS) (pg A41)									
Model Number	Length	Width	Height	Dim. Wt. Domestic Air	Dim. Wt. International Air & Ground	Actual Weight LBS./(kg)	Shipping Weight Ground	Add'l Shipping Charges	Box Girth
12FLS36209-* 12FLS36409-*	21	17	12	105	105	105 (47.5)	105		79
12FLS54213-* 12FLS54413-*	21	17	12	114	114	114 (52)	114		79
12FLS72219-* 12FLS72419-*	36	15	15	125	125	125 (57)	125		96
12FLS108226-* 12FLS108426-*	36	15	15	145	145	145 (66)	145		96
12FLS144233-* 12FLS144433-*	48	17	17	175	175	175 (79.5)	175	Too heavy for UPS	116
12FLS180241-* 12FLS180441-*	48	17	17	210	210	210 (95.5)	210	Too heavy for UPS	116
12FLS216249-* 12FLS216449-*	55	13	12	250	250	250 (114)	250	Too heavy for UPS	105

Should consider crating any over 80#

*******IF SHIPMENT CONTAINS MULTIPLE CARTONS OVER 130" IN GIRTH OR A COMBINED ACTUAL WEIGHT OVER 200 LBS. - LTL FREIGHT IS RECOMMENDED**

TOO LARGE FOR UPS

14FLS Flanged Metal Heaters

14FLS SERIES METAL HEATERS, 14" 150 LB. 316 STAINLESS FLANGE (45 ELEMENTS) (pg A41)									
Model Number	Length	Width	Height	Dim. Wt. Domestic Air	Dim. Wt. International Air & Ground	Actual Weight LBS./(kg)	Shipping Weight Ground	Add'l Shipping Charges	Box Girth
14FLS45209- 14FLS45409-*	21	17	12	110	110	110 (50)	110		79
14FLS67.5213- 14FLS67.5413-*	21	17	12	130	130	130 (59)	130		79
14FLS90219- 14FLS90419-*	36	15	15	150	150	150 (68)	150	Too heavy for UPS	96
14FLS135226- 14FLS135426-*	36	15	15	170	170	170 (77)	170	Too heavy for UPS	96
14FLS180233- 14FLS180433-*	48	17	17	195	195	195 (88.5)	195	Too heavy for UPS	116
14FLS225241- 14FLS225441-*	48	17	17	225	225	225 (102)	225	Too heavy for UPS	116
14FLS270249- 14FLS270449-*	55	13	12	270	270	270 (123)	270	Too heavy for UPS	105

Should consider crating any over 80#

*******IF SHIPMENT CONTAINS MULTIPLE CARTONS OVER 130" IN GIRTH OR A COMBINED ACTUAL WEIGHT OVER 200 LBS. - LTL FREIGHT IS RECOMMENDED**

TOO LARGE FOR UPS

R Series Quartz Infrared Heating Elements

R SERIES, QUARTZ INFRARED HEATING ELEMENTS, 22" OVERALL LENGTH - 18" HOT ZONE (pg A43)								
Model Number	Length	Width	Height	Dim. Wt. Domestic Air	Dim. Wt. International Air & Ground	Actual Weight LBS./(kg)	Shipping Weight Ground	Box Girth
R5221 R5222	33	13	12	27	34	10 (5)	27	83
R7221 R7222	33	13	12	27	32	10 (5)	27	83
R10221 R10222	33	13	12	27	32	10 (5)	27	83
R12221	33	13	12	27	32	10 (5)	27	83
R15221	33	13	12	27	32	10 (5)	27	83

R SERIES, QUARTZ INFRARED HEATING ELEMENTS, 34" OVERALL LENGTH - 30" HOT ZONE (pg A43)								
Model Number	Length	Width	Height	Dim. Wt. Domestic Air	Dim. Wt. International Air & Ground	Actual Weight LBS./(kg)	Shipping Weight Ground	Box Girth
R5341 R5342	44	13	12	36	42	12 (6)	36	94
R7341 R7342	44	13	12	36	42	12 (6)	36	94
R10341 R10342	44	13	12	36	42	12 (6)	36	94
R12341 R12342	44	13	12	36	42	12 (6)	36	94
R15341 R15342	44	13	12	36	42	12 (6)	36	94
R20341 R20342	44	13	12	36	42	12 (6)	36	94

R SERIES, QUARTZ INFRARED HEATING ELEMENTS, 46" OVERALL LENGTH - 42" HOT ZONE (pg A43)								
Model Number	Length	Width	Height	Dim. Wt. Domestic Air	Dim. Wt. International Air & Ground	Actual Weight LBS./(kg)	Shipping Weight Ground	Box Girth
R5461 R5462	55	13	12	45	52	15 (7)	45	105
R7461 R7462	55	13	12	45	52	15 (7)	45	105
R10461 R10462	55	13	12	45	52	15 (7)	45	105
R12461 R12462	55	13	12	45	52	15 (7)	45	105
R15461 R15462	55	13	12	45	52	15 (7)	45	105
R20461 R20462	55	13	12	45	52	15 (7)	45	105
R25462	55	13	12	45	52	15 (7)	45	105
R30462	55	13	12	45	52	15 (7)	45	105

*******IF SHIPMENT CONTAINS MULTIPLE CARTONS OVER 130" IN GIRTH OR A COMBINED ACTUAL WEIGHT OVER 200 LBS. - LTL FREIGHT IS RECOMMENDED**

R Series Quartz Infrared Heating Elements (cont.)

R SERIES, QUARTZ INFRARED HEATING ELEMENTS, 58" OVERALL LENGTH - 54" HOT ZONE (pg A43)								
Model Number	Length	Width	Height	Dim. Wt. Domestic Air	Dim. Wt. International Air & Ground	Actual Weight LBS./ (kg)	Shipping Weight Ground	Box Girth
R5581 R5582	67	13	12	54	63	18 (9)	54	117
R7581 R7582	67	13	12	54	63	18 (9)	54	117
R10581 R10582	67	13	12	54	63	18 (9)	54	117
R12581 R12582	67	13	12	54	63	18 (9)	54	117
R15581 R15582	67	13	12	54	63	18 (9)	54	117
R20581 R20582	67	13	12	54	63	18 (9)	54	117
R25582	67	13	12	54	63	18 (9)	54	117
R30582	67	13	12	54	63	18 (9)	54	117

R SERIES, QUARTZ INFRARED HEATING ELEMENTS, 70" OVERALL LENGTH - 66" HOT ZONE (pg A43)								
Model Number	Length	Width	Height	Dim. Wt. Domestic Air	Dim. Wt. International Air & Ground	Actual Weight LBS./ (kg)	Shipping Weight Ground	Box Girth
R10701 R10702	80	13	12	65	76	22 (10)	66	130 *****
R12701 R12702	80	13	12	65	76	22 (10)	66	130 *****
R15701 R15702	80	13	12	65	76	22 (10)	66	130 *****
R20701 R20702	80	13	12	65	76	22 (10)	66	130 *****
R25702	80	13	12	65	76	22 (10)	66	130 *****
R30702	80	13	12	65	76	22 (10)	66	130 *****
R35702	80	13	12	65	76	22 (10)	66	130 *****
R40702	80	13	12	65	76	22 (10)	66	130 *****

*******IF SHIPMENT CONTAINS MULTIPLE CARTONS OVER 130" IN GIRTH OR A COMBINED ACTUAL WEIGHT OVER 200 LBS. - LTL FREIGHT IS RECOMMENDED**

Grid Coils

G SERIES, METAL HEATING AND COOLING COILS, 12-1/2" WIDTH (8 tubes) (pg B1)									
Model Number	Length	Width	Height	Dim. Wt. Domestic Air	Dim. Wt. International Air & Ground	Actual Weight LBS./ (kg)	Shipping Weight Ground	Add'l Shipping Charges	Box Girth
*8G-24**	30	7	25	28	32	12 (5.5)	28		94
*8G-30**	40	7	25	37	43	14 (6.5)	37		104
*8G-36**	40	7	25	37	43	16 (7.5)	37		104
*8G-48**	49	4	37	38	44	18 (8)	38	\$40	131 *****
*8G-60**	62	6	37	71	83	23 (10.5)	71	\$40	148 *****
*8G-72**	74	6	37	85	99	28 (13)	85	\$40	160 *****
*8G-84**	86	6	37	99	116	31 (14)	31	\$40	172 *****
*8G-96**	97	6	37	111	130	34 (15.5)	34		183 *****
*8G-108**	110	14	25	199	232	38 (17)	38		188 *****
*8G-120**	124	14	25	224	262	41 (19)	41		202 *****
*8G-132**	134	14	25	242	283	46 (21)	46		212 *****
*8G-144**	150	14	25	271	317	49 (22)	49		228 *****

G SERIES, METAL HEATING AND COOLING COILS, 18-1/2" WIDTH (12 tubes) (pg B1)									
Model Number	Length	Width	Height	Dim. Wt. Domestic Air	Dim. Wt. International Air & Ground	Actual Weight LBS./ (kg)	Shipping Weight Ground	Add'l Shipping Charges	Box Girth
*12G-24**	40	7	25	37	43	15 (7)	37		104
*12G-30**	40	7	32	47	54	18 (8)	47		118
*12G-36**	49	4	37	38	44	21 (9.5)	38	\$40	131 *****
*12G-48**	49	4	37	38	44	26 (12)	38	\$40	131 *****
*12G-60**	62	6	37	71	83	32 (14.5)	71	\$40	148 *****
*12G-72**	74	6	37	85	99	37 (17)	85	\$40	160 *****
*12G-84**	86	6	37	99	116	42 (19)	42		172 *****
*12G-96**	97	6	37	111	130	47 (21)	47		183 *****
*12G-108**	110	14	32	255	297	53 (24)	53		202 *****
*12G-120**	124	14	32	287	335	58 (26)	58		216 *****
*12G-132**	134	14	32	310	362	64 (29)	64		226 *****
*12G-144**	150	14	32	347	405	69 (31)	69		242 *****

*****IF SHIPMENT CONTAINS MULTIPLE CARTONS OVER 130" IN GIRTH OR A COMBINED ACTUAL WEIGHT OVER 200 LBS. - LTL FREIGHT IS RECOMMENDED
 TOO LARGE FOR UPS

Grid Coils (cont.)

G SERIES, METAL HEATING AND COOLING COILS, 24-1/2" WIDTH (16 tubes) (pg B1)									
Model Number	Length	Width	Height	Dim. Wt. Domestic Air	Dim. Wt. International Air & Ground	Actual Weight LBS./ (kg)	Shipping Weight Ground	Add'l Shipping Charges	Box Girth
*16G-24**	40	7	25	37	43	19 (8.5)	37		104
*16G-30**	49	5	37	47	55	23 (10.5)	47	\$40	133 *****
*16G-36**	49	5	37	47	55	28 (13)	47	\$40	133 *****
*16G-48**	49	5	37	47	55	33 (15)	47	\$40	133 *****
*16G-60**	62	6	37	71	83	40 (18)	71	\$40	148 *****
*16G-72**	74	6	37	85	99	47 (19)	85		160 *****
*16G-84**	86	6	37	99	116	54 (24.5)	54		172 *****
*16G-96**	97	6	37	111	130	61 (28)	61		183 *****
*16G-108**	110	14	37	294	344	69 (31)	69		212 *****
*16G-120**	124	14	37	332	387	76 (34.5)	76		226 *****
*16G-132**	134	14	37	358	419	82 (37)	82		236 *****
*16G-144**	150	14	37	401	469	88 (40)	88		252 *****

G SERIES, METAL HEATING AND COOLING COILS, 30-1/2" WIDTH (20 tubes) (pg B1)									
Model Number	Length	Width	Height	Dim. Wt. Domestic Air	Dim. Wt. International Air & Ground	Actual Weight LBS./ (kg)	Shipping Weight Ground	Add'l Shipping Charges	Box Girth
*20G-24**	49	5	37	47	55	22 (10)	47	\$40	133 *****
*20G-30**	49	5	37	47	55	28 (13)	47	\$40	133 *****
*20G-36**	49	5	37	47	55	33 (15)	47	\$40	133 *****
*20G-48**	49	6	44	67	78	40 (18)	67	\$40	149 *****
*20G-60**	62	6	44	85	99	48 (22)	85	\$40	162 *****
*20G-72**	74	6	44	101	118	58 (26)	58		174 *****
*20G-84**	86	6	44	118	137	68 (31)	68		186 *****
*20G-96**	97	6	44	132	155	75 (34)	75		197 *****
*20G-108**	110	14	44	350	409	83 (38)	83		228 *****
*20G-120**	124	14	44	394	461	92 (42)	92		240 *****
*20G-132**	134	14	44	426	498	100 (45.5)	100		250 *****
*20G-144**	150	14	44	477	557	109 (49.5)	109		266 *****

*****IF SHIPMENT CONTAINS MULTIPLE CARTONS OVER 130" IN GIRTH OR A COMBINED ACTUAL WEIGHT OVER 200 LBS. - LTL FREIGHT IS RECOMMENDED
 ***** TOO LARGE FOR UPS

Grid Coils (cont.)

G SERIES, METAL HEATING AND COOLING COILS, 36-1/2" WIDTH (24 tubes) (pg B1)									
Model Number	Length	Width	Height	Dim. Wt. Domestic Air	Dim. Wt. International Air & Ground	Actual Weight LBS./(kg)	Shipping Weight Ground	Add'l Shipping Charges	Box Girth
*24G-24**	55	14	25	100	116	28 (13)	100	\$40	133 *****
*24G-30**	55	14	31	124	144	31 (14)	124	\$40	145 *****
*24G-36**	55	14	37	147	172	38 (17)	147	\$40	157 *****
*24G-48**	55	14	49	195	228	48 (22)	48		181 *****
*24G-60**	62	14	49	220	257	57 (26)	57		188 *****
*24G-72**	80	14	49	283	331	68 (31)	68		208 *****
*24G-84**	88	14	49	312	364	79 (36)	79		214 *****
*24G-96**	97	14	49	343	401	89 (40.5)	89		223 *****
*24G-108**	110	14	49	389	455	99 (45)	99		236 *****
*24G-120**	124	14	49	439	513	109 (49.5)	109		250 *****
*24G-132**	134	14	49	474	554	119 (54)	119		260 *****
*24G-144**	150	14	49	531	620	129 (59)	129		276 *****

G SERIES, METAL HEATING AND COOLING COILS, 42-1/2" WIDTH (28 tubes) (pg B1)									
Model Number	Length	Width	Height	Dim. Wt. Domestic Air	Dim. Wt. International Air & Ground	Actual Weight LBS./(kg)	Shipping Weight Ground	Add'l Shipping Charges	Box Girth
*28G-24**	55	14	25	100	116	32 (14.5)	100	\$40	133 *****
*28G-30**	55	14	31	124	144	38 (17)	124	\$40	145 *****
*28G-36**	55	14	37	147	172	45 (20.5)	147	\$40	157 *****
*28G-48**	55	14	49	195	228	56 (25.5)	56		181 *****
*28G-60**	62	14	55	247	288	57 (26)	57		200 *****
*28G-72**	80	14	55	318	372	80 (36.5)	80		218 *****
*28G-84**	88	14	55	350	409	92 (42)	92		226 *****
*28G-96**	97	14	55	385	450	103 (47)	103		235 *****
*28G-108**	110	14	55	437	511	115 (52)	115		248 *****
*28G-120**	124	14	55	493	576	126 (57)	126		262 *****
*28G-132**	134	14	55	532	622	140 (64)	140		272 *****
*28G-144**	150	14	55	596	696	150 (68)	150		288 *****

*******IF SHIPMENT CONTAINS MULTIPLE CARTONS OVER 130" IN GIRTH OR A COMBINED ACTUAL WEIGHT OVER 200 LBS. - LTL FREIGHT IS RECOMMENDED**
TOO LARGE FOR UPS

Serpentine Coils

SP4 SERIES, COILS (coil depth 36") (pg B2)									
Model Number	Length	Width	Height	Dim. Wt. Domestic Air	Dim. Wt. International Air & Ground	Actual Weight LBS./ (kg)	Shipping Weight Ground	Add'l Shipping Charges	Box Girth
SP4-24	30	7	25	28	32	10 (4.5)	28		94
SP4-36	49	5	36	46	54	12 (5.5)	46	\$40	131 *****
SP4-48	49	5	36	46	54	14 (6.5)	46	\$40	131 *****
SP4-60	62	6	36	70	81	16 (7.5)	70	\$40	146 *****
SP4-78	96	6	36	107	125	24 (11)	107	Too large for UPS	180 *****
SP4-96	110	13	36	266	311	34 (15.5)	266	Too large for UPS	208 *****

SP6 SERIES, COILS (coil depth 48") (pg B2)									
Model Number	Length	Width	Height	Dim. Wt. Domestic Air	Dim. Wt. International Air & Ground	Actual Weight LBS./ (kg)	Shipping Weight Ground	Add'l Shipping Charges	Box Girth
SP6-20	49	5	36	46	54	12 (5.5)	46	\$40	131 *****
SP6-30	49	5	36	46	54	14 (6.5)	46	\$40	131 *****
SP6-40	49	6	44	67	78	17 (8)	67	\$40	149 *****
SP6-50	60	6	49	91	107	20 (9)	91	\$40	170 *****
SP6-60	62	6	49	94	110	24 (11)	94	Too large for UPS	172 *****
SP6-70	72	6	49	110	128	27 (12.5)	110	Too large for UPS	182 *****

*******IF SHIPMENT CONTAINS MULTIPLE CARTONS OVER 130" IN GIRTH OR A COMBINED ACTUAL WEIGHT OVER 200 LBS. - LTL FREIGHT IS RECOMMENDED**

TOO LARGE FOR UPS

U Coils

UC SERIES, 12" COIL WIDTH (pg B3)								
Model Number	Length	Width	Height	Dim. Wt. Domestic Air	Dim. Wt. International Air & Ground	Actual Weight LBS./(kg)	Shipping Weight Ground	Box Girth
UC-18	20	9	10	10	11	3 (1.5)	3	58
UC-24	25	11	12	18	20	4 (2)	4	71
UC-30	33	13	12	27	32	5 (2.5)	5	83
UC-36	42	12	12	32	37	6 (3)	32	90
UC-42	44	13	12	36	42	7 (3)	36	94
UC-48	55	13	12	45	52	8 (3.5)	45	105
UC-54	55	13	12	45	52	9 (4)	45	105
UC-60	62	13	12	50	59	10 (4.5)	50	112

*******IF SHIPMENT CONTAINS MULTIPLE CARTONS OVER 130" IN GIRTH OR A COMBINED ACTUAL WEIGHT OVER 200 LBS. - LTL FREIGHT IS RECOMMENDED**

X & CX Fluoropolymer Heat Exchangers

X SERIES, FLUOROPOLYMER HEAT EXCHANGERS (pg B5)								
Model Number	Length	Width	Height	Dim. Wt. Domestic Air	Dim. Wt. International Air & Ground	Actual Weight LBS./ (kg)	Shipping Weight Ground	Box Girth
X1-12-12-18-F	33	13	12	27	32	10 (4.5)	10	83
X2-12-12-18-F	33	13	12	27	32	11 (5)	11	83
X2-16-16-22-F	33	14	24	58	67	13 (6)	58	109
X4-16-16-22-F	33	14	24	58	67	14 (6.5)	58	109
X2-18-18-24-F-LP	33	14	24	58	67	18 (8)	58	109
X4-18-18-24-F-LP	33	14	24	58	67	22 (10)	58	109
X6-18-18-24-F-LP	33	14	24	58	67	26 (12)	58	109
X8-18-18-24-F-LP	33	14	24	58	67	30 (13.5)	58	109
X2-24-24-30-F-LP	42	13	26	74	86	24 (11)	74	120
X4-24-24-30-F-LP	42	13	26	74	86	30 (13.5)	74	120
X6-24-24-30-F-LP	42	13	26	74	86	36 (16.5)	74	120
X8-24-24-30-F-LP	42	13	26	74	86	42 (19)	74	120

CX SERIES, HELICAL FLUOROPOLYMER (PFA) HEAT EXCHANGERS (pg B6)								
Model Number	Length	Width	Height	Dim. Wt. Domestic Air	Dim. Wt. International Air & Ground	Actual Weight LBS./ (kg)	Shipping Weight Ground	Box Girth
CX.5-11	20	9	10	10	11	2 (1)	2	58
CX1-11	20	9	10	10	11	2 (1)	2	58
CX1.5-11	20	9	10	10	11	3 (1.5)	3	58
CX2-17	24	11	12	17	20	3 (1.5)	3	70
CX2.5-23	24	11	12	17	20	4 (2)	4	70

*******IF SHIPMENT CONTAINS MULTIPLE CARTONS OVER 130" IN GIRTH OR A COMBINED ACTUAL WEIGHT OVER 200 LBS. - LTL FREIGHT IS RECOMMENDED**

CXL, 3CX & 3CXL Fluoropolymer Heat Exchangers

CXL SERIES, HELICAL L-SHAPED FLUOROPOLYMER (PFA) HEAT EXCHANGERS (pg B7)								
Model Number	Length	Width	Height	Dim. Wt. Domestic Air	Dim. Wt. International Air & Ground	Actual Weight LBS./(kg)	Shipping Weight Ground	Box Girth
CXL5.06-R12	20	9	10	10	11	3 (1.5)	3	58
CXL1.06-R12	20	9	10	10	11	3 (1.5)	3	58
CXL1.5.08-R12	20	9	10	10	11	4 (2)	4	58
CXL2.12-R18	24	11	12	17	20	5 (2.5)	5	70
CXL2.5.12-R18	24	11	12	17	20	5 (2.5)	5	70

3CX SERIES, TRIPLE HELICAL FLUOROPOLYMER (PFA) HEAT EXCHANGERS (pg B8)								
Model Number	Length	Width	Height	Dim. Wt. Domestic Air	Dim. Wt. International Air & Ground	Actual Weight LBS./(kg)	Shipping Weight Ground	Box Girth
3CX1.5-11	21	17	12	23	26	5 (2.5)	5	79
3CX3-11	21	17	12	23	26	6 (3)	6	79
3CX4.5-11	21	17	12	23	26	9 (4)	9	79
3CX6-17	21	17	12	23	26	9 (4)	9	79
3CX7.5-23	33	13	12	27	32	11 (5)	11	83

3CXL SERIES, TRIPLE HELICAL L-SHAPED FLUOROPOLYMER (PFA) HEAT EXCHANGERS (pg B9)								
Model Number	Length	Width	Height	Dim. Wt. Domestic Air	Dim. Wt. International Air & Ground	Actual Weight LBS./(kg)	Shipping Weight Ground	Box Girth
3CXL1.5.06-R12	21	17	12	23	26	6 (3)	23	79
3CXL3.06-R12	21	17	12	23	26	7 (3)	23	79
3CXL4.5.08-R12	21	17	12	23	26	9 (4)	23	79
3CXL6.12-R18	21	17	12	23	26	10 (4.5)	23	79
3CXL7.5.12-R18	21	17	12	23	26	12 (5.5)	23	79

*******IF SHIPMENT CONTAINS MULTIPLE CARTONS OVER 130" IN GIRTH OR A COMBINED ACTUAL WEIGHT OVER 200 LBS. - LTL FREIGHT IS RECOMMENDED**

Thermax Heat Exchangers

THERMAX ² SERIES, 316 STAINLESS HEAT EXCHANGERS (pg B10)								
Model Number	Length	Width	Height	Dim. Wt. Domestic Air	Dim. Wt. International Air & Ground	Actual Weight LBS./ (kg)	Shipping Weight Ground	Box Girth
IS1.1-2.75-6.25	20	9	10	10	11	5 (2.5)	5	58
IS2.5-2.75-10.25	20	9	10	10	11	7 (3)	7	58
IS3.8-2.75-14.25	20	9	10	10	11	10 (4.5)	10	58
IS3.8-3.75-10.75	20	9	10	15	15	15 (7)	15	58
IS5.8-3.75-15.5	20	9	10	20	20	20 (9)	20	58
IS7.8-3.75-20.25	24	11	12	24	24	24 (11)	24	70
IS15-4.75-20.25	24	11	12	30	30	30 (13.5)	30	70

*******IF SHIPMENT CONTAINS MULTIPLE CARTONS OVER 130" IN GIRTH OR A COMBINED ACTUAL WEIGHT OVER 200 LBS. - LTL FREIGHT IS RECOMMENDED**

Brass Solenoid Valves

S SERIES, BRASS SOLENOID VALVES (Water Service) (pg B15)								
Model Number	Length	Width	Height	Dim. Wt. Domestic Air	Dim. Wt. International Air & Ground	Actual Weight LBS./(kg)	Shipping Weight Ground	Box Girth
S-5-W	10	10	7	4	5	3 (1.5)	3	44
S-3-W	10	10	7	4	5	4 (2)	4	44
S-1-W	10	10	10	6	7	6 (3)	6	50
S-1-1/4-W	10	10	10	8	8	8 (4)	8	50
S-1-1/2-W	10	10	10	10	10	10 (4.5)	10	50
S-2-W	10	10	10	12	12	12 (5.5)	12	50

S SERIES, BRASS SOLENOID VALVES (Steam Service) (pg B15)								
Model Number	Length	Width	Height	Dim. Wt. Domestic Air	Dim. Wt. International Air & Ground	Actual Weight LBS./(kg)	Shipping Weight Ground	Box Girth
S-5-S	10	10	7	4	5	3 (1.5)	3	44
S-3-S	10	10	7	4	5	4 (2)	4	44
S-1-S	10	10	10	6	7	6 (3)	6	50
S-1-1/4-S	10	10	10	8	8	8 (4)	8	50
S-1-1/2-S	10	10	10	10	10	10 (4.5)	10	50
S-2-S	10	10	10	12	12	12 (5.5)	12	50

*******IF SHIPMENT CONTAINS MULTIPLE CARTONS OVER 130" IN GIRTH OR A COMBINED ACTUAL WEIGHT OVER 200 LBS. - LTL FREIGHT IS RECOMMENDED**

ST Strainers, IX Insulators & VB Vacuum Breakers

ST SERIES, STRAINERS (pg B16)								
Model Number	Length	Width	Height	Dim. Wt. Domestic Air	Dim. Wt. International Air & Ground	Actual Weight LBS./(kg)	Shipping Weight Ground	Box Girth
ST5	10	10	7	4	5	2 (1)	2	44
ST3	10	10	7	4	5	2 (1)	2	44
ST1	10	10	7	4	5	3 (1.5)	3	44
ST1-1/4	10	10	7	4	5	4 (2)	4	44
ST1-1/2	10	10	7	6	6	6 (3)	6	44
ST2	10	10	7	7	7	7 (3.5)	7	44
ST2-1/2	10	10	7	9	9	9 (4)	9	44

IX SERIES, COIL INSULATORS/ISOLATORS (pg B13)								
Model Number	Length	Width	Height	Dim. Wt. Domestic Air	Dim. Wt. International Air & Ground	Actual Weight LBS./(kg)	Shipping Weight Ground	Box Girth
IX-5	10	10	7	4	5	1 (.5)	1	44
IX-3	10	10	7	4	5	1 (.5)	1	44
IX-1	10	10	7	4	5	1 (.5)	1	44
IX-1-1/4	10	10	7	4	5	1 (.5)	1	44
IX-1-1/2	10	10	7	4	5	1 (.5)	1	44
IX-2	10	10	7	4	5	1 (.5)	1	44

VB SERIES, VACUUM BREAKERS (pg B14)								
Model Number	Length	Width	Height	Dim. Wt. Domestic Air	Dim. Wt. International Air & Ground	Actual Weight LBS./(kg)	Shipping Weight Ground	Box Girth
VB-5	12	8	1	2	2	2 (1)	2	30

*******IF SHIPMENT CONTAINS MULTIPLE CARTONS OVER 130" IN GIRTH OR A COMBINED ACTUAL WEIGHT OVER 200 LBS. - LTL FREIGHT IS RECOMMENDED**

NR Thermostats and Combination Controls

NR SERIES, NON-INDICATING THERMOSTATS SINGLE PHASE (pg C1)								
Model Number	Length	Width	Height	Dim. Wt. Domestic Air	Dim. Wt. International Air & Ground	Actual Weight LBS./ (kg)	Shipping Weight Ground	Box Girth
NR25	10	10	10	6	7	3 (1.5)	3	50
NR25-12	10	10	10	6	7	3 (1.5)	3	50
NR25H	10	10	10	6	7	3 (1.5)	3	50

NR SERIES, NON-INDICATING COMBINATION CONTROLS (pg C2)								
Model Number	Length	Width	Height	Dim. Wt. Domestic Air	Dim. Wt. International Air & Ground	Actual Weight LBS./ (kg)	Shipping Weight Ground	Box Girth
NR302	21	17	12	23	26	15 (5.5)	15	79
NR304	21	17	12	23	26	15 (5.5)	15	79
NR502	21	17	12	23	26	16 (6)	16	79
NR504	21	17	12	23	26	16 (6)	16	79
NR752	21	17	12	23	26	22 (8)	22	79
NR754	21	17	12	23	26	22 (8)	22	79
NR902	21	17	12	24	26	24 (9)	24	79
NR904	21	17	12	24	26	24 (9)	24	79
NR1202	21	17	12	26	26	26 (10)	26	79
NR1204	21	17	12	26	26	26 (10)	26	79
NR1502	21	17	12	32	32	32 (12)	32	79
NR1504	21	17	12	32	32	32 (12)	32	79

*******IF SHIPMENT CONTAINS MULTIPLE CARTONS OVER 130" IN GIRTH OR A COMBINED ACTUAL WEIGHT OVER 200 LBS. - LTL FREIGHT IS RECOMMENDED**

NE Thermostats and Combination Controls

NE SERIES, NON-INDICATING ELECTRONIC THERMOSTATS (pg C5)								
Model Number	Length	Width	Height	Dim. Wt. Domestic Air	Dim. Wt. International Air & Ground	Actual Weight LBS./ (kg)	Shipping Weight Ground	Box Girth
NE20	10	10	10	6	7	3 (1.5)	3	50
NE20H	10	10	10	6	7	3 (1.5)	3	50

NE SERIES, NON-INDICATING ELECTRONIC COMBINATION CONTROLS, 1 OR 3 PHASE (pg C6)								
Model Number	Length	Width	Height	Dim. Wt. Domestic Air	Dim. Wt. International Air & Ground	Actual Weight LBS./ (kg)	Shipping Weight Ground	Box Girth
NE302	21	17	12	23	26	15 (5.5)	15	79
NE304	21	17	12	23	26	15 (5.5)	15	79
NE502	21	17	12	23	26	16 (6)	16	79
NE504	21	17	12	23	26	16 (6)	16	79
NE752	21	17	12	23	26	22 (8)	22	79
NE754	21	17	12	23	26	22 (8)	22	79
NE902	21	17	12	24	26	24 (9)	24	79
NE904	21	17	12	24	26	24 (9)	24	79
NE202	21	17	12	26	26	26 (10)	26	79
NE1204	21	17	12	26	26	26 (10)	26	79
NE1502	21	17	12	32	32	32 (12)	32	79
NE1504	21	17	12	32	32	32 (12)	32	79

*******IF SHIPMENT CONTAINS MULTIPLE CARTONS OVER 130" IN GIRTH OR A COMBINED ACTUAL WEIGHT OVER 200 LBS. - LTL FREIGHT IS RECOMMENDED**

DE Digital Thermostats and Combination Controls

DE SERIES, 1/8 DIN DIGITAL THERMOSTATS (pg C7)								
Model Number	Length	Width	Height	Dim. Wt. Domestic Air	Dim. Wt. International Air & Ground	Actual Weight LBS./ (kg)	Shipping Weight Ground	Box Girth
DE20	10	10	7	4	5	3 (1.5)	3	44
DE20-1-PB	21	17	12	23	26	12 (5.5)	12	79

DE SERIES, DIGITAL COMBINATION CONTROLS (pg C8)								
Model Number	Length	Width	Height	Dim. Wt. Domestic Air	Dim. Wt. International Air & Ground	Actual Weight LBS./ (kg)	Shipping Weight Ground	Box Girth
DE302	21	17	12	23	26	16 (6)	16	79
DE304	21	17	12	23	26	16 (6)	16	79
DE502	21	17	12	23	26	17 (8)	17	79
DE504	21	17	12	23	26	17 (8)	17	79
DE752	21	17	12	23	26	23 (10.5)	23	79
DE754	21	17	12	23	26	23 (10.5)	23	79
DE902	21	17	12	25	26	25 (11.5)	25	79
DE904	21	17	12	25	26	25 (11.5)	25	79
DE1202	21	17	12	27	27	27 (12.5)	27	79
DE1204	21	17	12	27	27	27 (12.5)	27	79
DE1502	21	17	12	33	33	33 (15)	33	79
DE1504	21	17	12	33	33	33 (15)	33	79

*******IF SHIPMENT CONTAINS MULTIPLE CARTONS OVER 130" IN GIRTH OR A COMBINED ACTUAL WEIGHT OVER 200 LBS. - LTL FREIGHT IS RECOMMENDED**

DQ Digital Thermostats and Combination Controls

DQ SERIES, 1/4 DIN DIGITAL THERMOSTATS (pg C9)								
Model Number	Length	Width	Height	Dim. Wt. Domestic Air	Dim. Wt. International Air & Ground	Actual Weight LBS./ (kg)	Shipping Weight Ground	Box Girth
DQ15D	10	10	10	6	7	3 (1.5)	3	50
DQ15D-1-PB	21	17	12	23	26	12 (5.5)	12	79

DQ SERIES, DIGITAL COMBINATION CONTROLS (pg C10)								
Model Number	Length	Width	Height	Dim. Wt. Domestic Air	Dim. Wt. International Air & Ground	Actual Weight LBS./ (kg)	Shipping Weight Ground	Box Girth
DQ302	21	17	12	23	26	16 (6)	16	79
DQ304	21	17	12	23	26	16 (6)	16	79
DQ502	21	17	12	23	26	17 (8)	17	79
DQ504	21	17	12	23	26	17 (8)	17	79
DQ752	21	17	12	23	26	23 (10.5)	23	79
DQ754	21	17	12	23	26	23 (10.5)	23	79
DQ902	21	17	12	25	26	25 (11.5)	25	79
DQ904	21	17	12	25	26	25 (11.5)	25	79
DQ1202	21	17	12	27	27	27 (12.5)	27	79
DQ1204	21	17	12	27	27	27 (12.5)	27	79
DQ1502	21	17	12	33	33	33 (15)	33	79
DQ1504	21	17	12	33	33	33 (15)	33	79

*******IF SHIPMENT CONTAINS MULTIPLE CARTONS OVER 130" IN GIRTH OR A COMBINED ACTUAL WEIGHT OVER 200 LBS. - LTL FREIGHT IS RECOMMENDED**

DSL Digital Thermostats and Combination Controls

DSL SERIES, 1/16 DIN DIGITAL THERMOSTATS (PG C11)								
Model Number	Length	Width	Height	Dim. Wt. Domestic Air	Dim. Wt. International Air & Ground	Actual Weight LBS./(kg)	Shipping Weight Ground	Box Girth
DSL	10	10	7	4	5	2 (1)	2	44
DSL-1-PB	21	17	12	23	26	12 (5.5)	12	79

DSL SERIES, DIGITAL COMBINATION CONTROLS (pg C12)								
Model Number	Length	Width	Height	Dim. Wt. Domestic Air	Dim. Wt. International Air & Ground	Actual Weight LBS./(kg)	Shipping Weight Ground	Box Girth
DSL302	21	17	12	23	26	16 (6)	16	79
DSL304	21	17	12	23	26	16 (6)	16	79
DSL502	21	17	12	23	26	17 (8)	17	79
DSL504	21	17	12	23	26	17 (8)	17	79
DSL752	21	17	12	23	26	23 (10.5)	23	79
DSL754	21	17	12	23	26	23 (10.5)	23	79
DSL902	21	17	12	25	26	25 (11.5)	25	79
DSL904	21	17	12	25	26	25 (11.5)	25	79
DSL1202	21	17	12	27	27	27 (12.5)	27	79
DSL1204	21	17	12	27	27	27 (12.5)	27	79
DSL1502	21	17	12	33	33	33 (15)	33	79
DSL1504	21	17	12	33	33	33 (15)	33	79

*******IF SHIPMENT CONTAINS MULTIPLE CARTONS OVER 130" IN GIRTH OR A COMBINED ACTUAL WEIGHT OVER 200 LBS. - LTL FREIGHT IS RECOMMENDED**

DLC Digital Thermostats and Combination Controls

DLC SERIES, DIGITAL THERMOSTATS (pg C13)								
Model Number	Length	Width	Height	Dim. Wt. Domestic Air	Dim. Wt. International Air & Ground	Actual Weight LBS./ (kg)	Shipping Weight Ground	Box Girth
DLC16-1	10	10	10	6	7	3 (1.5)	3	50
DLC16-2	10	10	10	6	7	3 (1.5)	3	50
DLC16-1-PB	10	10	10	6	7	3 (1.5)	3	50
DLC16-2-PB	10	10	10	6	7	3 (1.5)	3	50

DLC SERIES, DIGITAL COMBINATION CONTROLS (pg C13a)								
Model Number	Length	Width	Height	Dim. Wt. Domestic Air	Dim. Wt. International Air & Ground	Actual Weight LBS./ (kg)	Shipping Weight Ground	Box Girth
DLC302	21	17	12	23	26	16 (6)	16	79
DLC304	21	17	12	23	26	16 (6)	16	79
DLC502	21	17	12	23	26	17 (8)	17	79
DLC504	21	17	12	23	26	17 (8)	17	79
DLC752	21	17	12	23	26	23 (10.5)	23	79
DLC754	21	17	12	23	26	23 (10.5)	23	79
DLC902	21	17	12	25	26	25 (11.5)	25	79
DLC904	21	17	12	25	26	25 (11.5)	25	79
DLC1202	21	17	12	27	27	27 (12.5)	27	79
DLC1204	21	17	12	27	27	27 (12.5)	27	79
DLC1502	21	17	12	33	33	33 (15)	33	79
DLC1504	21	17	12	33	33	33 (15)	33	79

*******IF SHIPMENT CONTAINS MULTIPLE CARTONS OVER 130" IN GIRTH OR A COMBINED ACTUAL WEIGHT OVER 200 LBS. - LTL FREIGHT IS RECOMMENDED**

LC & ESP Liquid Level Controls

LC SERIES, CONDUCTIVITY TYPE REMOTE LIQUID LEVEL CONTROL (pg C14)								
Model Number	Length	Width	Height	Dim. Wt. Domestic Air	Dim. Wt. International Air & Ground	Actual Weight LBS./ (kg)	Shipping Weight Ground	Box Girth
LC3(*) 6	20	9	10	10	11	5 (2)	5	58
LC3(*) 12	20	9	10	10	11	5 (2)	5	58
LC3(*) 18	24	11	12	17	20	6 (2.5)	6	70
LC3(*) 24	33	13	12	27	32	7 (3)	7	83
LC3(*) 30	42	12	12	32	37	8 (3.5)	32	90
LC3(*) 36	42	12	12	32	37	9 (4)	32	90
LC3(*) 48	55	13	12	45	52	11 (5)	45	105

REPLACEMENT PROBE ASSEMBLIES (pg C14)								
Model Number	Length	Width	Height	Dim. Wt. Domestic Air	Dim. Wt. International Air & Ground	Actual Weight LBS./ (kg)	Shipping Weight Ground	Box Girth
3(*) 6	13	6	5	3	3	3 (1.5)	3	35
3(*) 12	20	9	10	10	11	6 (1.5)	6	58
3(*) 18	33	9	6	10	11	4 (2)	4	63
3(*) 24	33	9	6	10	11	6 (2.5)	6	63
3(*) 30	45	9	6	13	15	7 (3)	7	75
3(*) 36	45	9	6	13	15	8 (3.5)	8	75
3(*) 48	55	13	12	45	52	9 (4)	45	105

ESP SERIES, CAPACITIVE TYPE LIQUID LEVEL CONTROLS (pg C15)								
Model Number	Length	Width	Height	Dim. Wt. Domestic Air	Dim. Wt. International Air & Ground	Actual Weight LBS./ (kg)	Shipping Weight Ground	Box Girth
ESP	10	10	7	4	5	1 (.5)	1	44

*******IF SHIPMENT CONTAINS MULTIPLE CARTONS OVER 130" IN GIRTH OR A COMBINED ACTUAL WEIGHT OVER 200 LBS. - LTL FREIGHT IS RECOMMENDED**

ETI Series, DTS Series, AHM Series & W Series

ETI SERIES, ELECTRONIC TEMPERATURE INDICATORS (pg C20)								
Model Number	Length	Width	Height	Dim. Wt. Domestic Air	Dim. Wt. International Air & Ground	Actual Weight LBS./ (kg)	Shipping Weight Ground	Box Girth
ETI-1	10	10	10	6	7	3 (1.5)	3	50
ETIH-1	10	10	10	6	7	3 (1.5)	3	50

DTS SERIES, DIGITAL TIMERS (pg C16)								
Model Number	Length	Width	Height	Dim. Wt. Domestic Air	Dim. Wt. International Air & Ground	Actual Weight LBS./ (kg)	Shipping Weight Ground	Box Girth
DTS-1	13	6	5	3	3	1 (.5)	1	35
DTS-1-PB	13	6	5	3	3	1 (.5)	1	35

AHM SERIES, AMP-HOUR METER (pg C21)								
Model Number	Length	Width	Height	Dim. Wt. Domestic Air	Dim. Wt. International Air & Ground	Actual Weight LBS./ (kg)	Shipping Weight Ground	Box Girth
AHM	10	10	10	6	7	3 (1.5)	3	50

W SERIES, OVER THE SIDE THERMOWELLS (pg C19)								
Model Number	Length	Width	Height	Dim. Wt. Domestic Air	Dim. Wt. International Air & Ground	Actual Weight LBS./ (kg)	Shipping Weight Ground	Box Girth
W(*)12	13	6	5	3	3	2 (1)	2	35
W(*)24	33	9	6	10	11	2 (1)	2	63
W(*)36	45	9	6	13	15	2 (1)	2	75

W SERIES, THERMOWELLS WITH 1/2" NPT FITTING (pg C19)								
Model Number	Length	Width	Height	Dim. Wt. Domestic Air	Dim. Wt. International Air & Ground	Actual Weight LBS./ (kg)	Shipping Weight Ground	Box Girth
W(*)T12	13	6	5	3	3	2 (1)	2	35
W(*)T24	33	9	6	10	11	2 (1)	2	63
W(*)T36	45	9	6	13	15	2 (1)	2	75

*******IF SHIPMENT CONTAINS MULTIPLE CARTONS OVER 130" IN GIRTH OR A COMBINED ACTUAL WEIGHT OVER 200 LBS. - LTL FREIGHT IS RECOMMENDED**

SD Series Conduit & Fittings

SD SERIES, PVC CONDUIT (pg C17)								
Model Number	Length	Width	Height	Dim. Wt. Domestic Air	Dim. Wt. International Air & Ground	Actual Weight LBS./ (kg)	Shipping Weight Ground	Box Girth
SD 3/8	12	14	8	7	9	5 (2.5)	5	56
SD 1/2	20	20	6	13	15	7 (3)	7	72
SD 3/4	20	20	6	13	15	10 (4.5)	10	72
SD 1	25	25	8	26	31	14 (6.5)	14	91
SD1-1/4	25	25	8	26	31	19 (9)	19	91
SD 1-1/2	25	25	8	26	31	23 (10.5)	23	91
SD 2	25	25	8	28	31	28 (13)	28	91

SD SERIES STRAIGHT FITTINGS (pg C17)								
Model Number	Length	Width	Height	Dim. Wt. Domestic Air	Dim. Wt. International Air & Ground	Actual Weight LBS./ (kg)	Shipping Weight Ground	Box Girth
SD 3/8-S	10	10	7	4	5	2 (1)	2	44
SD 1/2-S	10	10	7	4	5	2 (1)	2	44
SD 3/4-S	10	10	7	4	5	2 (1)	2	44
SD-1-S	10	10	7	4	5	2 (1)	2	44
SD 1-1/4-S	10	10	7	4	5	2 (1)	2	44
SD 1-1/2-S	10	10	7	4	5	2 (1)	2	44
SD 2-S	10	10	7	4	5	2 (1)	2	44

SD SERIES, 90° ELBOW FITTINGS (pg C17)								
Model Number	Length	Width	Height	Dim. Wt. Domestic Air	Dim. Wt. International Air & Ground	Actual Weight LBS./ (kg)	Shipping Weight Ground	Box Girth
SD 3/8-EL	10	10	7	4	5	2 (1)	2	44
SD 1/2-EL	10	10	7	4	5	2 (1)	2	44
SD 3/4-EL	10	10	7	4	5	2 (1)	2	44
SD-1-EL	10	10	7	4	5	2 (1)	2	44
SD 1-1/4-EL	10	10	7	4	5	2 (1)	2	44
SD 1-1/2-EL	10	10	7	4	5	2 (1)	2	44
SD 2-EL	10	10	7	4	5	2 (1)	2	44

*******IF SHIPMENT CONTAINS MULTIPLE CARTONS OVER 130" IN GIRTH OR A COMBINED ACTUAL WEIGHT OVER 200 LBS. - LTL FREIGHT IS RECOMMENDED**

Appendix

UPS Information Regarding Dimensional Weight

If your package has a large size-to-weight ratio, you may need to consider your package's dimensional weight when you calculate your shipping rates.

Learn about Dimensional Weight

Determining which weight to use in calculating your rate requires that you determine which rule applies. Different rules apply depending on the service selected. Dimensional weight considers density, which is the amount of space a package occupies in relation to its actual weight, to determine billable weight. Calculations of dimensional weight are based on the International Air Transport Association (IATA) volumetric standards (subject to change without notice).

Packages that exceed UPS weight and size limits are not accepted for transportation. If found in the UPS system, they are subject to an Over Maximum Limits charge.

How To Measure the Cubic Size of Your Package

Calculate the cubic size of your package by multiplying the height in inches or centimeters, by the length in inches or centimeters, by the width in inches or centimeters. Round each measurement to the nearest whole inch or centimeter. The resulting total is the cubic size of your package.

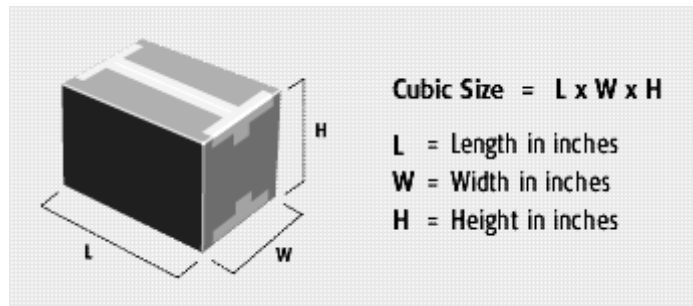

Calculating Dimensional Weight for Domestic Shipments

If you have more than one package to be shipped, consider each package a separate shipment for weight calculation purposes:

Determine the Actual Weight: Use any standard scale and round up any fraction of a pound to the next full pound.

Determine Dimensional Weight:

For UPS Ground Shipments: If the cubic size of the package is 5,184 or larger, divide the cubic size by 194 to determine dimensional weight in pounds. If the cubic size is less than 5,184, use the actual weight of the package.

For UPS Air Shipments: Divide the cubic size by 194 to determine dimensional weight in pounds. Round up any fraction of a pound to the next full pound.

Determine Billable Weight: Compare each package's actual weight to its dimensional weight. The larger of the two weights is the billable weight and should be used to calculate the rate.

Appendix (cont.)

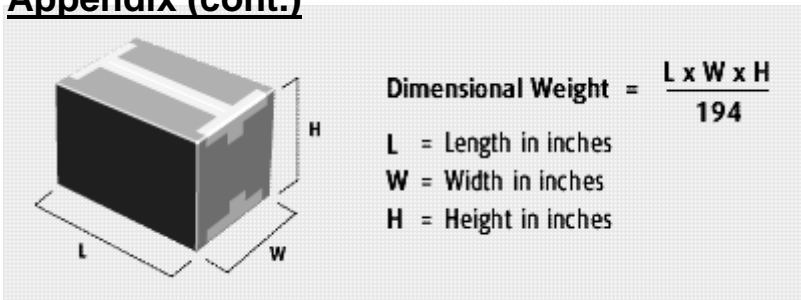

If you have a multiple-package shipment, add the cubic sizes for all of the packages together. The total is the cubic size of your shipment.

Large Package Conditions

Your UPS domestic or UPS Standard to Canada package is considered a Large Package when its length, combined with twice the width plus twice the height, exceeds 130 inches and is equal to or less than 165 inches. Large Packages are subject to a minimum billable weight of 90 pounds. To determine the rate for single-package shipments with a dimensional weight of 150 pounds or more, multiply the package weight by the price per pound multiplier.

Large Package Surcharge

A Large Package Surcharge of US\$40 will be applied to all UPS domestic packages, including Hundredweight and Standard to Canada packages, when the size of the package exceeds 130 inches (330 cm) in length and girth combined.

Calculating Dimensional Weight for International Shipments

Use dimensional weight as the billable weight when the dimensional weight of your packages exceeds their actual weight, for your international shipments using these services: UPS Worldwide Express PlusSM, UPS Worldwide ExpressSM, UPS Worldwide SaverSM, UPS Worldwide ExpeditedSM, UPS 3 Day SelectSM from Canada, UPS Standard from Canada, or UPS Standard to Canada, follow these guidelines to determine your shipping rate:

Determine Actual Weight: Use any standard scale and round up any fraction of a pound to the next full pound.

Determine Dimensional Weight:

For UPS Worldwide Express, UPS Worldwide Saver, UPS Worldwide Expedited, and UPS Standard from Canada shipments:

Divide the cubic size by 166 if measured in inches, or by 6,000 if measured in centimeters, to determine the dimensional weight. To convert metric measurements into pounds, multiply the result by 2.20462. Increase any fraction to the next pound.

For UPS Standard to Canada shipments: If the cubic size of the package is 5,184 cubic inches (84,951 cubic centimeters) or greater, divide the cubic size by 166 if measured in inches or by 6,000 if measured in centimeters, to determine the dimensional weight. To convert metric measurements into pounds, multiply the result by 2.20462. Round up any fraction to the next full pound. If the cubic size is less than 5,184, use the actual weight of the package.

For the dimensional weight of your package in kilograms, divide the cubic size of your package in centimeters by 6,000. Increase your total to the nearest full kilogram.

Determine Billable Weight: Compare each package's/shipment's actual weight to its dimensional weight. The larger of the two weights is the billable weight and should be used to calculate the rate.

