



T SERIES, 2" TUBULAR SCREW PLUG HEATERS							
WATTS	VOLTS	OVERALL LENGTH In./(mm)	PIPE THREAD	304 SS	316 SS	TITANIUM	SHIP WGT. Lbs./(kg)
1000	120	10	2	FT1110	ST1110	TT1110	11
	240	(255)		FT1210	ST1210	TT1210	(5)
2000	120	14	2	FT2114	ST2114	TT2114	14
	240	(355)		FT2214	ST2214	TT2214	(6.5)
	480			FT2414	ST2414	TT2414	
3000	240	19	2	FT3219	ST3219	TT3219	16
	480	(485)		FT3419	ST3419	TT3419	(7.5)
4000	240	23	2	FT4223	ST4223	TT4223	20
	480	(585)		FT4423	ST4423	TT4423	(9)
6000	240	33	2	FT6233	ST6233	TT6233	26
	480	(840)		FT6433	ST6433	TT6433	(12)
8000	240	40	2	FT8240	ST8240	TT8240	29
	480	(1015)		FT8440	ST8440	TT8440	(13.5)
9000	240	47	2	FT9247	ST9247	TT9247	32
	480	(1195)		FT9447	ST9447	TT9447	(14.5)
12000	240	61	2	FT12261	ST12261	TT12261	37
	480	(1550)		FT12461	ST12461	TT12461	(17)

Other sizes available, consult factory.

Product Features and Benefits:

- ◆ **SUPERIOR CHEMICAL RESISTANCE:** Materials available for use in most aqueous alkaline, plating solutions and rinse tanks. Check solution recommendation chart or with your chemical supplier for proper sheath material selection.
- ◆ **RUGGED CONSTRUCTION:** Heavy wall metal sheaths and screwplug available in:
 - 304 stainless steel.
 - 316 stainless steel.
 - Titanium.
- ◆ **OUTSTANDING PERFORMANCE:** Watt densities of 35 watts per square inch (5.4 w/cm²) ensure long service life.
- ◆ **CORROSION RESISTANT HEAD:** Vapor resistant, flame retardant polypropylene terminal enclosure with 3-foot (.9m) flexible PVC liquid tight conduit.
- ◆ **SAFETY FEATURES:**
 - Grounded construction
- ◆ **CERTIFICATIONS:** UL listed (except steel) to U.S. and Canadian safety requirements, and CE.
- ◆ **SIZES:** 1,000 watts to 12,000 watts.
- ◆ **VOLTAGES:** 120 to 600 volts. Single phase standard, three phase available.
- ◆ **OPTIONS AVAILABLE (consult factory):**
 - Special configurations and lengths.
 - Explosion resistant enclosures
 - Longer wire and conduit lengths.
 - Lower watt densities for highly viscous solutions.
 - Temperature and level controls sized to match the heater.

DIMENSIONS

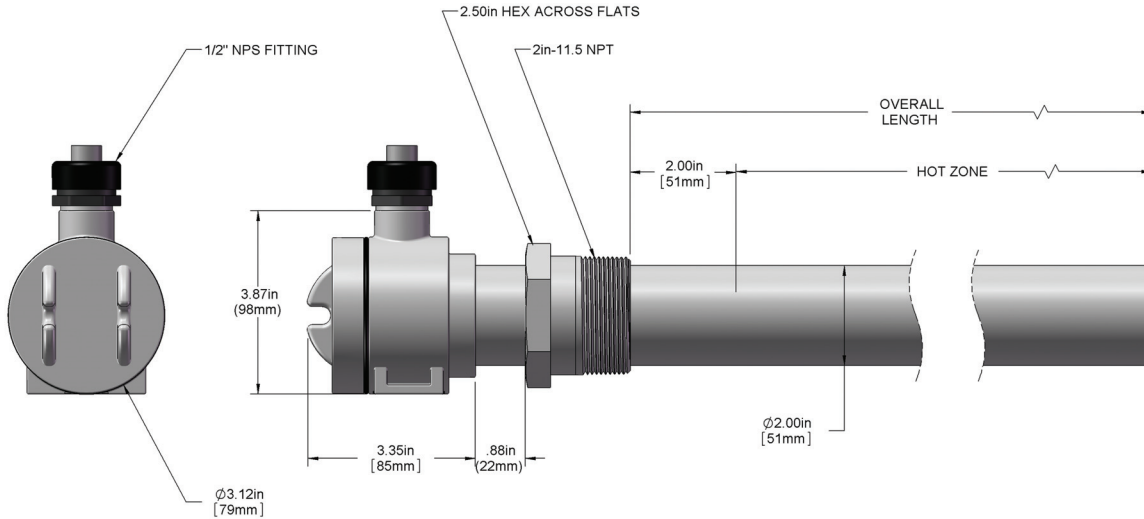

2" TUBULAR SCREW PLUG HEATER ORDERING INFORMATION

Series	Wattage	Voltage	Length (in.)	Options	Wire and Conduit Length
1 = 1000 2 = 2000 3 = 3000 4 = 4000 6 = 6000 8 = 8000 9 = 9000 12 = 12000	1 = 120 2 = 240 3 = 380 4 = 480 5 = 415 6 = 600 7 = 400 8 = 208 9 = 220 0 = 200	10 = 1kW 14 = 2kW 19 = 3kW 23 = 4kW 33 = 6kW 40 = 8kW 47 = 9kW 61 = 12kW specify (custom lengths available)	no designator = single phase power (standard) -3 = three phase power no designator = 36" length standard specify variations from standard Ex: -X84 = 84"	1 inch = 25.4mm	
FT = 304 stainless steel ST = 316 stainless steel TT = titanium					

ORDERING EXAMPLE:

FT12261
 304 stainless steel, 12,000 watts, 240 volts, 61" overall length.

